

**G:B:D:**

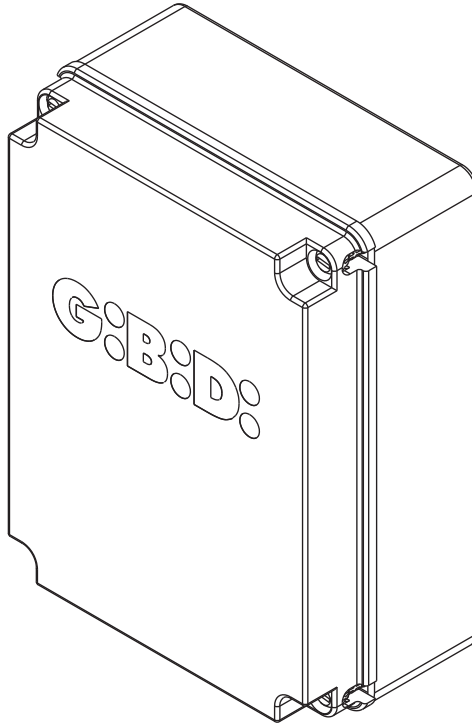

**:SC**

**CE**

**SC380 (AS05800 - AS05810)**

**Electronic control unit**  
INSTRUCTIONS FOR INSTALLATION

**UK**

UK

- This product has been tested by G.I.B.I.D.I., checking the perfect correspondance of its characteristics to the current directive.
- G.I.B.I.D.I. S.r.l. reserves the right to modify the technical data without prior notice, depending on the product development.

**PLEASE READ CAREFULLY THIS MANUAL BEFORE PROCEEDING WITH THE INSTALLATION.**



## WARNING

- The control unit is provided without jumper for the selection of the supply voltage.
- Before powering the control unit, it is necessary to make a jumper on terminal M12, according to the supply voltage you want to use.

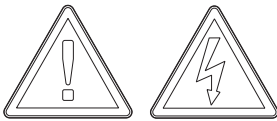

**230 Vac**

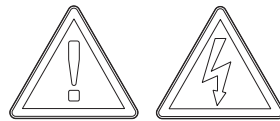
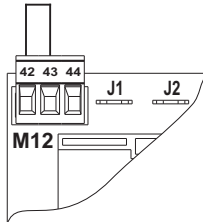

**380 Vac**

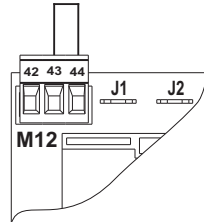

## 1 - SPECIFICATION SHEET

Control unit	SC380	
Code	AS05800	AS05810
Type	<b>Electronic control unit for the automation of one 230Vac or 380Vac motor for swinging or sliding gates.</b>	
Power supply	230Vac Monophase 50/60 Hz 230 / 380Vac Three-phase 50/60 Hz	
Line disconnecter	Yes	No
N° motors	1	
Motor power supply	230Vac Monophase 50/60 Hz 230 / 380Vac Three-phase 50/60 Hz	
Flashing light	230Vac 40W max	
Warning light	24Vdc 3W max	
Electric lock	Managed by relay with free contact	
Accessories power supply	24Vdc 8W max	
Safety devices power supply		
Safety devices test	Yes	
Energy saving	Yes	
Radio receiver	Plug-in	
Operating temperature	-20°C +60°C	
Protection degree	IP 55	

## UK

## 2 - TECHNICAL SPECIFICATIONS AND FUNCTIONS

- Red warning leds of NC contacts. There is not the safety devices led (from terminals 24 to 28). See "SIGNALLING LED" table.
- Green warning leds of NO contacts. See "SIGNALLING LED" table.
- Management of 1 electric lock by a relay with free contact.
- Management of 1 electric magnet by a relay with free contact.
- Management of the courtesy light by a relay with free contact.
- Safety test run before the opening and closing movement.
- Photocell test run before the opening and closing movement.
- Motion stop and inversion for 2 seconds after the intervention of the safety devices.
- Additional attempts (till 5) after the intervention of safety devices to allow the restart of the motion.
- Safety devices test.
- Energy saving (ENERGY SAVING).
- Digital programming of all functions.
- Working time adjustable independently in opening and closing.
- Adjustable pedestrian working time.
- Adjustable pause time, differentiated for complete or pedestrian opening.
- 4 possible working functions (step by step, step by step with stop, condominium or automatic, dead man).
- Possibility of choosing the system configuration between swinging and sliding gate.
- Setting of 5 safety inputs, selectable as inputs: STOP-RESISTIVE NC-RESISTIVE 8K2-PHOTO1-PHOTO2.
- Setting of:
  - Automatic closing.
  - Fast closing.
  - Pre-flashing.
  - Hammer stroke.
  - Final opening and closing stroke.
  - Courtesy light.
  - Fixed or intermittent flashing light.
  - Reserve input with 3 different operating modes.
  - Hydraulic block maintenance.
  - Number of cycles for scheduled maintenance.
  - Installer password.
- Display of the number of cycles done and of the number of power supply days.
- Possibility of powering the control unit and 230V monophase 50/60Hz or 230 / 380V three-phase 50/60Hz motor.
- Main line switch (disconnecter 16A )with door locking device (code AS05800).
- Motor braking always active at each stop (if in sliding operator mode).
- Synchronism with a different control unit allowed with simplified wiring.
- Motor revolutions sensor for obstacle detection and motion inversion.

### 3 - INSTALLATION WARNINGS

- Use suitable cable glands to assure the correct mechanical connection of the wiring and maintain the Ip55 protection degree of the case.
- Before proceeding with the installation, it is necessary to fit a magnetothermal and differential switch with a maximum capacity of 10A upstream of the system. The switch must guarantee an omnipolar separation of the contacts, with an opening distance of at least 3 mm.
- To prevent possible interference, differentiate and always keep the power cables (minimum section 1,5mm<sup>2</sup>) separate from the signal cables (minimum section 0,5mm<sup>2</sup>).
- Make the connections referring to this manual. Connect in series all the devices that must be connected to the same N.C. (normally closed) input and in parallel all the devices that share the same N.O. (normally open) input. Incorrect installation or improper use of the product may compromise the safety of the system.
- Keep all the materials contained in the packaging away from children, since they pose a potential risk.
- The manufacturer declines all responsibility for improper functioning of the automated device, if the original components and accessories, suitable for the specific automation, are not used.
- At the end of the installation, always check carefully the proper functioning of the system and the devices used.
- This instruction manual addresses people qualified for the installation of "live equipment". Therefore good technical knowledge and professional practice in compliance with the regulations in force are required.
- Maintenance must be carried out by qualified personnel.
- Before carrying out any cleaning or maintenance operation, disconnect the control unit from the mains.
- This control unit may only be used for the purpose for which it was designed.
- The use of the product for purposes different from the intended use has not been tested by the manufacturer. Therefore any work is carried out on full responsibility of the installer.
- Mark the automated gate with visible warning plates.
- Warn the user that children or animals may not play or stand around near the gate.
- Appropriately protect the dangerous points (for example, use one or more sensitive frames).

### 4 - WARNINGS FOR THE USER

- In the event of an operating fault or failure, cut the power upstream of the control unit and call the Technical Service.
- Periodically check the functioning of the safety devices. Any repair must be carried out by specialised personnel using original and certified materials.
- The appliance is not to be used by children or people with reduced physical, sensory or mental capabilities, or lack of experience and knowledge, unless they have been given supervision or instruction.

**WARNING: IMPORTANT SAFETY INSTRUCTIONS.**

It is very important to follow these instructions for your own safety.

Please keep this instruction manual.

## UK

## 5 - ELECTRICAL CONNECTIONS: TRANSFORMER

Faston	Cable colour	Description	Fig.
J1	Brown	Primary 380 Vac transformer	3
J2	Black	Primary 230 Vac transformer	
J3	Grey	Primary 0 Vac transformer	
J4	Red	Secondary 14 Vac transformer	
J5			
J6	Blue	Secondary 22 Vac transformer	
J7			

## 6 - ELECTRICAL CONNECTIONS: TERMINAL BOARDS

Terminal	Position	Signal	Description	Fig.
M1	1	GND	Ground wire connection	9
	2			
M2	3	Motor	Motor connection	10
	4		Motor connection	11
	5		Motor connection	12
M3	6	Lamp	230 Vac 40 W flashing light output (Menu C2)	13
	7			
M4	8	REL1 Menu 32	Free contact (NO)	14
	9		(Menu E 32)	
M5	10	REL2 Menu 34	Free contact (NO)	15
	11		(Menu E 34)	
M6	12	R	230 Vac / 380 Vac power supply input	6
	13	S		7
	14	T		8

## 6 - ELECTRICAL CONNECTIONS: TERMINAL BOARDS

Terminal	Position	Signal	Description	Fig.
M7	15	Start	Start Input ( NO )	16
	16	Ped	Pedestrian input (NO)	
	17	Open	Opening only input (NO)	
	18	Close	Closing only input ( NO )	
	19	FCA	Opening limit switch input (NC) (Menu C4)	17
	20	FCC	Closing limit switch input (NC) (Menu C4)	
	21	Reserve	Multifunction input (NC) (Menu E9)	18 19
	22	COM	Inputs common - Outputs	
	23			
M8	24	Photo 1	Programmable safety device input (Default Menu C40 = Photocell 1 NC )	20 ↓ 32
	25	Photo 2	Programmable safety device input (Default Menu C41 = not active)	
	26	Safety 1	Programmable safety device input (Default Menu C42 = not active)	
	27	Safety 2	Programmable safety device input (Default Menu C43 = not active)	
	28	Stop	Programmable safety device input (Default Menu C44 = STOP )	
	29	COM	Inputs common - Outputs	
M9	30	Warning light	Warning light output + 24 Vdc 3W Synchronized with Flashing light during the motion and on with open gate if C2=2 otherwise fixed on	33
	31	+ ACC	Power supply +24 Vdc (external accessories)	
	32	ENERGY SAVING	Power supply + 24 Vdc for the safety devices Test and Energy Saving (menu E1-E3-E4)	
	33	COM	Inputs common - Outputs	

## UK

## 6 - ELECTRICAL CONNECTIONS: TERMINAL BOARDS

Terminal	Position	Signal	Description	Fig.
M10	34	IMP	Motor revolutions sensor input	34
	35	+24 Vcc	Power supply +24 Vdc Motor revolutions sensor	
	36	COM	Inputs common - Outputs and Negative - 24 Vdc	
	37	OPT	Not used	
M11	38	S1	Synchronization connection with another one SC 380	35
	39	S2		
	40	S3		
	41	S4		
M12	42	Transformer	Transformer connection for power supply at 230 Vac	6
	43		Transformer common	7
	44		Power supply Transformer connection at 380 Vac	8



## 7 - SIGNALLING LED

Position	Colour	Signal	Description	Fig.
DL 1	GREEN	START	Turns on when the START command is enabled and turns off at release	4 5
DL 2	GREEN	PEDESTR.	Turns on when the PEDESTRIAN command is enabled and turns off at release.	
DL 3	GREEN	OPEN	Turns on when the OPEN command is enabled and turns off at release.	
DL 4	GREEN	CLOSE	Turns on when the CLOSE command is enabled and turns off at release.	
DL 5	RED	FCA	Always turned on. It turns off when reaching the OPENING LIMIT SWITCH of the motor.	
DL 6	RED	FCC	Always turned on. It turns off when reaching the CLOSING LIMIT SWITCH of the motor.	
DL 7	RED	RESERVE	Turns on when the contact is closed and stays turned on till the contact do not open again.	
DL 8	RED	IMP	State of motor revolutions sensor.	
DL 9	RED	-	Not used	
DL 10	RED	S3	Closing command of synchronized control units	35
DL 11	YELLOW	VCC	Presence indicator of control unit power supply.	4 5

**WARNING:**

The signalling LED will be visible at rest only if the ENERGY SAVING is DISABLED (Menu E4)

## 8 - PROTECTION FUSES

Position	Value	Type	Description	Fig.
F 1	1 A	FAST	Primary protection of transformer and electronic card	3
F 2	6,3 A	FAST	Motor protection	
F 3				
F 4				

UK

## 9 - DISPLAY FROM LCD

M8

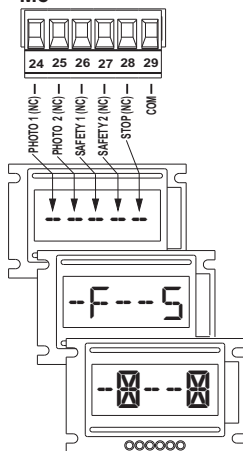

The contacts of terminal M8 are multifunction and can be programmed with menus C40-C41-C42-C43-C44, in the manual they will be identified with the name of their default or primary function.

*During rest phase (Close gate) it is possible to display on the LCD the state of safety contacts (terminal M8).*

This display indicates that the contacts of reference ( 24 ) ( 25 ) ( 26 ) ( 27 ) ( 28 ) are closed or excluded.

This display with letters indicates that the contacts of reference PHOTO 2 ( 25 ) and STOP ( 28 ) are opened

This display with blinking asterisk indicates that the contacts of reference PHOTO 2 ( 25 ) and STOP ( 28 ) have intervened during the motion and have determined the gate's stop. This signalling occurs only if the contacts are programmed as FRAME 8K2, FRAME NC or STOP.



This display with blinking inscription indicates that the gate's stop has been caused by the intervention of the motor revolutions sensor.

*During gate's motion it is possible to display on the LCD the state of the gate*

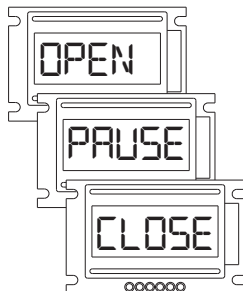

The OPEN inscription indicates that the gate is in opening phase

The PAUSE inscription indicates that the gate is in pause phase

The CLOSE inscription indicates that the gate is in closing phase

## 10 - BUTTONS DESCRIPTION

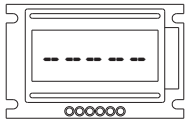

*At rest the buttons have the following functions*

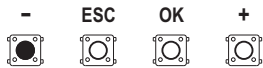

Button ( - ) to enable the PEDESTRIAN command

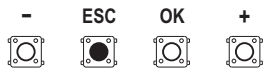

Button ( ESC ) is not enabled

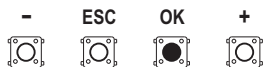

Button ( OK ) is enabled to activate STOP command



Button ( + ) is enabled to activate START command

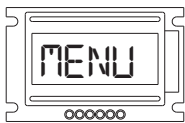

*During programming phase the buttons have the following functions:*



The buttons ( - and + ) are of use for:

- moving to or fro on the display
- moving from a menu to the other one
- increasing or decreasing a value

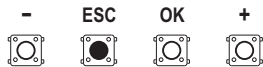

The button ( ESC ) is of use for:

- moving from sub-menus to main menus
- going out from the programming pushing ( ESC ) for 3 sec



The button ( OK ) is of use for :

- entering the menus
- confirming and storing the vaues set

UK

## 11 - PROGRAMMING, ACCESS AND PASSWORD INSERTION

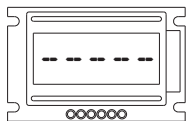

With control unit at rest press the buttons ( ESC and OK ) at the same time for 3 seconds, it will immediately appear MENU, then PASS.

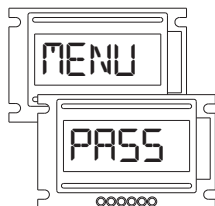

To go on with the programming, press button ( OK )  
To go out from the programming, press button ( ESC ) for 3 seconds.



( 0000 ) will appear with the first digit blinking.

By DEFAULT PASSWORD ( 0000 ) you enter the SIMPLIFIED mode, in this case the available MENUS are the following:

- A3 - operation logic
- A5 - automatic closing
- H1 - opening time of the motor
- H2 - closing time of the motor
- H9 - pause time with automatic reclosing
- E94 - firmware version

By DEFAULT PASSWORD ( 1234 ) you enter all the MENUS.

The PASSWORD is customizable by the MENU E92, the new PASSWORD will disable the use of DEFAULT PASSWORDS.

The DEFAULT PASSWORDS can be recovered making a reset of the control unit.

12 - PROGRAMMING, EXAMPLE OF PASSWORD ( 0000 ) INSERTION

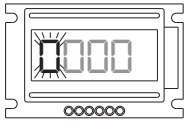

Make the access to the programming as described in chapter 11.  
Press the button ( OK ) to confirm.

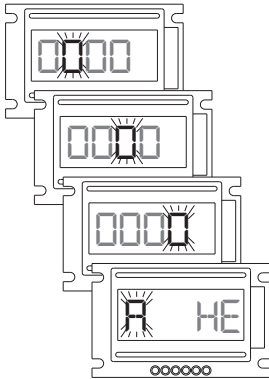
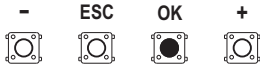

The second digit will blink  
Press the button ( OK ) to confirm

The third digit will blink  
Press the button ( OK ) to confirm

The fourth digit will blink  
Press the button ( OK ) to confirm

The letters of the accessible MENUS will be displayed and the first one will blink.  
If you want to leave the programming, press the button ( ESC ) for 3 seconds.

13 - PROGRAMMING, EXAMPLE PASSWORD ( 1234 ) INSERTION

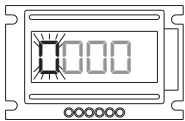

Make the access to the programming as described in chapter 11.  
Press the button ( + ) to display the number [1].  
Press the button ( OK ) to confirm.

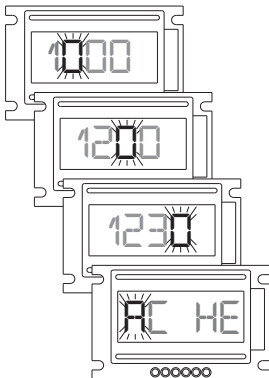
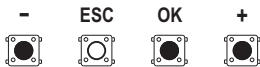

The button (ESC) is not enabled till PASSWORD confirmation

The second digit will blink, use the button ( + ) till display the number (2).  
Press the button ( OK ) to confirm

The third digit will blink, use the button ( + ) till display the number (3).  
Press the button ( OK ) to confirm

The fourth digit will blink, use the button ( + ) till display the number (4).  
Press the button ( OK ) to confirm

The letters of the accessible MENUS will be displayed and the first one will blink.  
If you want to leave the programming, press the button ( ESC ) for 3 seconds.

## UK

## 14 - PROGRAMMING, EXAMPLE OF SETTING E9=4

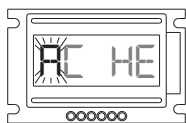

The procedure used in this example for MENU (E) is valid for MENUS (A, C) also.

Make the access to the programming as described in chapters 11 and 13.

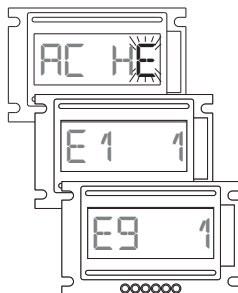

Use the buttons (+ or -) to scroll the letters, stop when (E) blinks.

Press the button (OK).

Use the buttons (+ or -) to scroll the sub-menus, stop when (E9 1) is displayed.

The button (ESC) is enabled only to come back to the previous MENU.

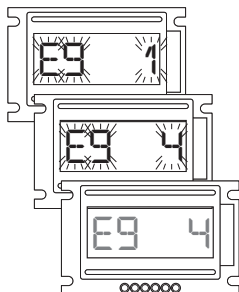

Press the button (OK), the display will start blinking  
**WARNING** In this phase the button (ESC) is not enabled.

Use the buttons (+ or -) to increase or decrease the value till displaying (E9 4)

Press the button (OK).  
The programming of E9 = 4 is finished.

15 - PROGRAMMING, EXAMPLE OF SETTING H2 = 20

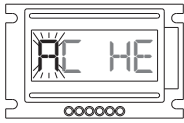

*The procedure used in this example for MENU (H) is valid also for MENU (E) with 4 digits settings .*

Make the access to the programming as described in chapters 11 and 13.

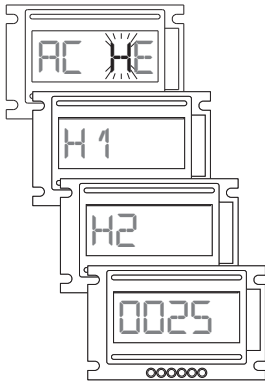
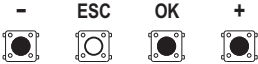

Use the buttons ( + or - ) to scroll the letters, stop when (H) blinks.

Press the button ( OK ).

Use the buttons ( + or - ) to scroll the sub-menus, stop when (H2) is displayed.

Press the button ( OK ).

The button (ESC) is enabled only to come back to the previous MENU.

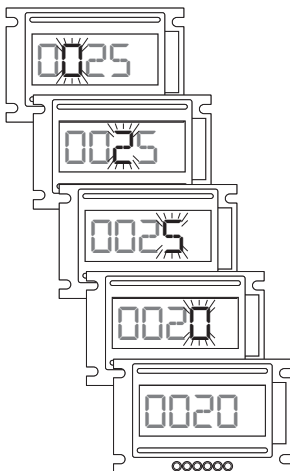

Press the button ( OK ), the second digit will start blinking. **WARNING** In this phase the button ( ESC ) is not enabled.

Use the button (OK) till making the digit you must modify blink.

Use the buttons ( + or - ) to increase or decrease the value, till displaying ( 0020 )

Press the button ( OK ).  
The programming of H2 =20 is finished.

UK

## 16 - PROGRAMMING, GO OUT FROM THE PROGRAMMING

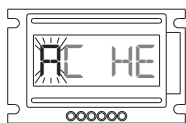

It is possible to leave the programming from the main menu pressing the button (ESC) for 3 seconds.

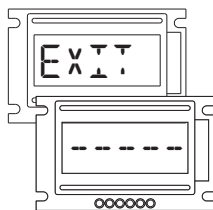

## 17 - RESET PROCEDURE

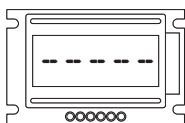

*It is possible to make a reset of the control unit to come back to factory parameters.*

**WARNING : all the settings done will be lost, except the ones concerning revolutions made and power supply days**

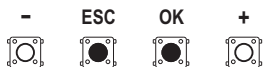

Press buttons (ESC) and (OK) at same time for 3 seconds.



(PASS) will appear on the display



Press buttons (+ and -) at same time for 3 seconds.

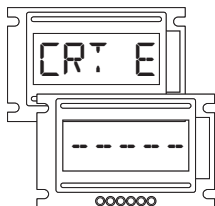

(CRT E) will appear to indicate that the procedure has had a successful conclusion.

The display will show the opening screen.

The reset procedure is finished



## 18 - DEFAULT CONFIGURATION

## • Parameters type A

- A1 → 3 SLIDING GATE TYPE
- A3 → 2 STEP BY STEP WITH STOP LOGIC
- A5 → 2 AUTOMATIC CLOSING ENABLED (TOTAL AND PEDESTRIAN)

## • Parameters type C

- C1 → 1 FAST CLOSING DISABLED
- C2 → 2 INTERMITTENT FLASHING LIGHT
- C3 → 2 PRE-FLASHING ENABLED
- C4 → 2 LIMIT SWITCH READING ENABLED
- C10 → 1 WATER HAMMER DISABLED
- C11 → 1 FINAL STROKE DISABLED
- C13 → 1 HYDRAULIC BLOCK MAINTENANCE EXCLUDED
- C40 → 3 SAFETY 1 INPUT = PHOTO 1
- C41 → 1 SAFETY 2 INPUT = not active
- C42 → 1 SAFETY 3 INPUT = not active
- C43 → 1 SAFETY 4 INPUT = not active
- C44 → 2 SAFETY 5 INPUT= STOP

## • Parameters type H

- H1 → 25 MOTOR OPENING TIME
- H2 → 25 MOTOR CLOSING TIME
- H9 → 20 PAUSE TIME
- H10 → 5 PEDESTRIAN OPENING TIME
- H11 → 20 PEDESTRIAN PAUSE TIME
- H19 → 10 WAITING TIME FOR REPEATED ATTEMPTS AFTER THE INTERVENTION OF SAFETY DEVICES

## • Parameters type E

- E1 → 1 PHOTO 1 TEST DISABLED
- E3 → 1 SAFETY DEVICES TEST DISABLED
- E4 → 1 ENERGY SAVING DISABLED
- E5 → 1 IN PEDESTRIAN CLOSING IT ENABLES THE COMPLETE REOPENING
- E9 → 1 EXTERNAL CLOCK CONTACT DISABLED
- E30 → 0 THE INTERVENTION OF REVOLUTIONS FRAME/SENSOR BLOCKS THE GATE
- E32 → 2 RELAY\_1 SET AS ELECTRIC LOCK
- E34 → 3 RELAY\_2 SET AS COURTESY LIGHT
- E36 → 1 MOTOR REVOLUTIONS SENSOR DISABLED
- E90 → 0000 CYCLES NUMBER BEFORE MAINTENANCE WARNING DISABLED
- E92 → 1234 PASSWORD

## UK

## 19 - MENU DESCRIPTION

**WARNING:**

The **DEFAULT** settings are in grey spaces



## 19.1 - DESCRIPTION MENU ( A )

Menu	Function	Status	Description
A 1	TYPE OF INSTALLATION	2	It configures the system for swing gate.  With this configuration: •the electronic brake is automatically excluded.
		3	It configures the system for sliding gate  With this configuration it will be automatically: •active the electronic brake. •excluded the water hammer. •excluded the final stroke. •excluded the hydraulic block maintenance. •active the limit switch reading.  NOTA BENE: Menus C4, C10, C11, C13 are not visible any more.
A 3	STEP BY STEP WITH STOP LOGIC	2	It enables the STEP BY STEP WITH STOP Logic  <b>Operation after a START command :</b> • Close gate → OPEN • During opening → STOP • Open gate → CLOSE • During closing → STOP • After a STOP → invert the motion
	STEP BY STEP LOGIC	3	It enables the STEP BY STEP Logic  <b>Operation after a START command:</b> • Close gate → OPEN • During opening → CLOSE • Open gate → CLOSE • During closing → OPEN
	AUTOMATIC CONDOMINIUM LOGIC	4	It enables the AUTOMATIC Logic  <b>Operation after a START command:</b> • Close gate → OPEN • During opening → IRRELEVANT • Open gate → Reloads the automatic closing time if the automatic reclosing is enabled, otherwise it closes. • During closing → OPEN

## 19.1 - DESCRIPTION MENU ( A )

Menu	Function	Status	Description
A 3	DEAD MAN LOGIC	5	<p>It enables the DEAD MAN Logic</p> <p><b>Operation:</b></p> <ul style="list-style-type: none"> <li>• OPENING → opens only if you keep the OPENING button pressed.</li> <li>• CLOSING → closes only if you keep the CLOSING button pressed.</li> </ul>
A 5	AUTOMATIC CLOSING	1	<p>It disables the automatic closing.</p> <p><b>In pause</b> (open gate):</p> <ul style="list-style-type: none"> <li>• START will cause the closing.</li> <li>• The CLOSING button will activate the closing.</li> </ul>
		2	<p>It enables:</p> <ul style="list-style-type: none"> <li>• the <b>total</b> automatic closing (See Menu H9)</li> <li>• the <b>pedestrian</b> automatic closing (See Menu H11)</li> </ul>
		3	<p>It enables <b>only</b> the total automatic closing (See Menu H9)</p>
		4	<p>It enables <b>only</b> the pedestrian automatic closing (See Menu H11)</p>

## UK

## 19.2 - DESCRIPTION MENU ( C )

Menu	Function	Status	Description
C 1	FAST CLOSING	1	It disables the fast closing function. After the interception and the subsequent freeing of the photocells, the pause time will be reloaded.
		2	It enables the fast closing function.  <b>Operation:</b> Setting active only on photocell 1. It reduces the pause time to 3 seconds after the interception and subsequent freeing of the photocells.
C 2	230V FLASHING LIGHT	2	Blinking flashing light output (TERMINAL M3)
		3	Fixed flashing light output (TERMINAL M3)
C 3	PREFLASHING	1	It disables the pre-flashing function. The flashing light and motor will start at the same time.
		2	It enables the pre-flashing function. The flashing light will start 3 seconds before motor start.
C 4	LIMIT SWITCH	1	It disables the limit switch reading.
		2	It enables the limit switch reading.
C 10	HAMMER STROKE	1	It disables the hammer stroke function.
		2	It enables the hammer stroke function in opening to help the release of the electric lock (see menu E32 and menu E34).  <b>Operation:</b> After a START, OPENING or PEDESTRIAN command, the sequence is: <ul style="list-style-type: none"> <li>• enabling of the electric lock</li> <li>• 1 second pulse in closing</li> <li>• opening</li> <li>• after 2 seconds, disabling of the electric lock</li> </ul> <p>This function cannot be enabled with sliding configuration and is <b>not advised</b> with electromechanical operators.</p>

## 19.2 - DESCRIPTION MENU ( C )

Menu	Function	Status	Description
C 10	HAMMER STROKE	3	<p>It enables the hammer stroke function both in opening and closing to help the release of the electric lock (see menus E32 and E34).</p> <p><b>Operation:</b> After a START, OPENING, CLOSING or PEDESTRIAN command, the sequence is:</p> <ul style="list-style-type: none"> <li>• enabling of the electric lock</li> <li>• 1 second pulse in closing/opening</li> <li>• opening/closing</li> <li>• after 2 seconds, disabling of the electric lock</li> </ul> <p>This function cannot be enabled with sliding configuration and is <b>not advised</b> with electromechanical operators.</p>
C 11	FINAL STROKE IN OPENING AND CLOSING	1	It disables the final stroke in closing function
		2	<p>It enables the final stroke in closing</p> <p><b>Operation:</b></p> <ul style="list-style-type: none"> <li>• At the end of the <b>closing</b> manoeuvre, the gate motion goes for 2 seconds more.</li> <li>• The final stroke is not controlled by safety devices.</li> <li>• Not active with sliding configuration and dead man logic</li> </ul>
		3	<p>It enables the final stroke in opening and closing</p> <p><b>Operation:</b></p> <ul style="list-style-type: none"> <li>• At the end of <b>closing</b> or <b>opening</b> manoeuvre, the gate motion continues for 2 seconds more.</li> <li>• The final stroke is not controlled by safety devices.</li> <li>• Not active with sliding configuration and dead man logic</li> </ul>

## UK

## 19.2 - DESCRIPTION MENU ( C )

Menu	Function	Status	Description
C 13	HYDRAULIC BLOCK MAINTENANCE  (FOR HYDRAULIC OPERATORS ONLY)	1	It disables the "Hydraulic block maintenance" function
		2	It enables the "Hydraulic block maintenance" function.  <b>Operation:</b> When the gate is close and not active, a 2 seconds pulse is given in closing every hour. The enabling of STOP button in any moment disables the function. This function cannot be selected with SLIDING GATE or DEAD MAN configuration.
		3	It enables the "Hydraulic block maintenance" function  <b>Operation:</b> As previous selection but every 3 HOURS.
		4	It enables the "Hydraulic block maintenance" function  <b>Operation:</b> As previous selection but every 5 HOURS.
C 23	MANUAL CHECK OF LIMIT SWITCH POSITION	M1FCA	It enables the MANUAL check of the OPENING limit switch.  Moving the gate by hand towards opening, the flashing light will turn on (LAMP and REL1-REL2 if enabled as flashing lights) when it meets the opening limit switch.
		M1FCC	It enables the MANUAL check of the CLOSING limit switch  Moving the gate by hand towards closing, the flashing light will turn on (LAMP e REL1-REL2 if enabled as flashing lights) when it meets the closing limit switch.

## 19.2 - DESCRIPTION MENU ( C )

Menu	Function	Status	Description
C 40	programming of <b>SAFETY DEVICES</b> No.1input (terminal 24) named PHOTO 1	1	Input DISABLED.
		2	Input programmed as STOP  <b>Operation:</b> The STOP enabling blocks the automation and the restart of the motion will occur only after a START/PEDESTRIAN/OPEN/CLOSE command.
		3	Input programmed as PHOTOCELL 1  <b>Operation:</b> Input active only during the closing phase. It stops the motion and inverts, opening completely. If intercepted in pause, it reloads the pause time. If enabled, it allows the fast closing (see menu C1)
		4	Input programmed as PHOTOCELL 2 <b>Operation:</b> Input active both in opening and closing. If intercepted, it stops the motion and keeps it blocked till when it is not freed. At release the motion restarts always in opening. If intercepted in pause, it reloads the pause time.
		5	Input programmed as FRAME 8K2. <b>Operation:</b> Input active both in opening and closing. It stops the motion and inverts the movement for 2 seconds. The gate will keep blocked waiting for a command: • START/PEDESTRIAN, the movement restarts towards the obstacle freeing way. • OPEN/CLOSE, the motion restarts in opening or closing.
		6	Input programmed as FRAME N.C.  <b>Operation:</b> See description of FRAME 8K2 operation

UK

## 19.2 - DESCRIPTION MENU ( C )

Menu	Function	Status	Description
C 41	programming of <b>SAFETY DEVICES No.2</b> input (terminal 25) named PHOTO2	1	Input DISABLED.
		2	Input programmed as STOP <b>Operation:</b> STOP enabling blocks the automation and the restart of the motion will occur only after a START/PEDESTRIAN/OPEN/CLOSE command.
		3	Input programmed as PHOTOCELL 1 <b>Operation:</b> Input active only during the closing phase. It stops the motion and inverts opening completely. If intercepted in pause, it reloads the pause time. If enabled, it allows the fast closing (see menu C1)
		4	Input programmed as PHOTOCELL 2 <b>Operation:</b> Input active both in opening and closing. If intercepted, it stops the motion and keeps it blocked till when it is not freed. At release the motion restarts always in opening. If intercepted in pause, it reloads the pause time.
		5	Input programmed as FRAME 8K2. <b>Operation:</b> Input active both in opening and closing. It stops the motion and inverts the movement for 2 seconds. The gate will keep blocked waiting for a command: • START/PEDESTRIAN, the motion restarts towards the obstacle freeing way.
		6	Input programmed as FRAME N.C. <b>Operation:</b> See description of FRAME 8K2 operation



## 19.2 - DESCRIPTION MENU ( C )

Menu	Function	Status	Description
C 42	programming of the <b>SAFETY DEVICE No.3</b> input (terminal 26) named SAFETY 1	1	Input DISABLED.
		2	Input programmed as STOP  <b>Operation:</b> STOP enabling blocks the automation and the restart of the motion will occur only after a START/PEDESTRIAN/OPEN/CLOSE command.
		3	Input programmed as PHOTOCELL 1  <b>Operation:</b> Input active only during the closing phase. It stops the motion and inverts opening completely. If intercepted in pause, it reloads the pause time. If enabled, it allows the fast closing (see menu C1)
		4	Input programmed as PHOTOCELL 2  <b>Operation:</b> Input active both in opening and closing. If intercepted, it stops the motion and keeps it blocked till when it is not freed. At release the motion restarts always in opening. If intercepted in pause, it reloads the pause time.
		5	Input programmed as FRAME 8K2.  <b>Operation:</b> Input active both in opening and closing. It stops the motion and inverts the movement for 2 seconds. The gate will keep blocked waiting for a command: • START/PEDESTRIAN, the motion restarts towards the obstacle freeing way.
		6	Input programmed as FRAME N.C.  <b>Operation:</b> See description of FRAME 8K2 operation

UK

## 19.2 - DESCRIPTION MENU ( C )

Menu	Function	Status	Description
C 43	programming of <b>SAFETY DEVICES No.4</b> input (terminal 27) named SAFETY 2	1	Input DISABLED.
		2	Input programmed as STOP  <b>Operation:</b> The STOP enabling blocks the automation and the restart of the motion will occur only after a START/PEDESTRIAN/OPEN/CLOSE command.
		3	Input programmed as PHOTOCELL 1  <b>Operation:</b> Input active only during closing phase. It stops the motion and inverts opening completely. If intercepted in pause, it reloads the pause time. If enabled, it allows the fast closing (see menu C1)
		4	Input programmed as PHOTOCELL 2  <b>Operation:</b> Input active both in opening and closing. If intercepted, it stops the motion and keeps blocked till when it is not freed. At release the motion restarts always in opening. If intercepted in pause, it reloads the pause time.
		5	Input programmed as FRAME 8K2.  <b>Operation:</b> Input active both in opening and closing. It stops the motion and inverts the movement for 2 seconds. The gate will keep blocked waiting for a command: • START/PEDESTRIAN, the motion restarts towards the obstacle freeing way.
		6	Input programmed as FRAME N.C.  <b>Operation:</b> See description of FRAME 8K2 operation

## 19.2 - DESCRIPTION MENU ( C )

Menu	Function	Status	Description
C 44	programming of <b>SAFETY DEVICES No.5</b> input (terminal 28) named STOP	1	Input DISABLED.
		2	Input programmed as STOP  <b>Operation:</b> STOP enabling blocks the automation and motion restart will occur only after a START/PEDESTRIAN/OPEN/CLOSE command.
		3	Input programmed as PHOTOCELL 1 <b>Operation:</b> Input active only during the closing phase. It stops the motion and inverts opening completely. If intercepted in pause, it reloads the pause time. If enabled, it allows the fast closing (see menu C1)
		4	Input programmed as PHOTOCELL 2  <b>Operation:</b> Input active both in opening and closing. If intercepted, it stops the motion and keeps it blocked till when it is not freed. At release the motion restarts always in opening. If intercepted in pause, it reloads the pause time.
		5	Input programmed as FRAME 8K2.  <b>Operation:</b> Input active both in opening and closing. It stops the motion and inverts the movement for 2 seconds. The gate will keep blocked waiting for a command: • START/PEDESTRIAN, the motion restarts towards the obstacle freeing way.
		6	Input programmed as FRAME N.C.  <b>Operation:</b> See description of FRAME operation 8K2

## UK

## 19.3 - DESCRIPTION MENU ( H )

Menu	Function	Status	Description
H 1	MOTOR OPENING TIME	25	Door opening time. 0 - 300 seconds (adjustable at intervals of 1 second )
H 2	MOTOR CLOSING TIME	25	Door closing time. 0 - 300 seconds (adjustable at intervals of 1 second)
H 9	AUTOMATIC CLOSING PAUSE TIME	20	It determines the pause time in opening before the automatic closing. 0 - 300 seconds (adjustable at intervals of 1 second)
H 10	PEDESTRIAN OPENING TIME	5	It determines the pedestrian opening time.
H 11	PEDESTRIAN AUTOMATIC CLOSING PAUSE TIME	20	It determines the pause time in pedestrian opening before the automatic closing. 0 - 300 seconds (adjustable at intervals of 1 second)
H 19	WAITING TIME FOR REPEATED ATTEMPTS AFTER SAFETY DEVICES INTERVENTION	10	It determines the pause time before the automation restarts the motion that had been interrupted after an intervention of the FRAME and/or the MOTOR REVOLUTIONS SENSOR (see menu E30). 0 - 60 seconds (adjustable at intervals of 1 second)

## 19.4 - DESCRIPTION MENU ( E )

Menu	Function	Status	Description
E 1	SAFETY INPUTS TEST SET AS PHOTOCELL1 or PHOTOCELL2	1	it disables the photocell test
		2	It enables the test of all the safety inputs set as photocell 1 and photocell 2.  <b>Operation:</b> When the movement command of the gate (START, OPENING, CLOSING, ETC) is given, the power supply to transmitters is taken off for 1 second and then restored to check its correct operation. If the test fails, an anomaly is signalled by some blinkings of the flashing light, see chapter 22.  With this function active, there will be a certain delay between the opening/closing command and the enabling of the motor.

## 19.4 - DESCRIPTION MENU ( E )

Menu	Function	Status	Description
E 3	SAFETY DEVICES TEST SET AS FRAME	1	It disables the safety devices test.
		2	<p>This function enables the safety devices test SET AS FRAME 8K2 or FRAME NC.</p> <p><b>Operation for FRAME 8K2:</b> All the safety inputs set as frame 8K2, after a command motion start will be tested (8K2 value). If the value will not be corrected, the anomaly will be signalled by some blinkings of the flashing light, see chapter 22.</p> <p><b>Operation for FRAME NC:</b> To check these devices it is necessary a suitable electronic card. When the command of gate movement (START, OPENING, CLOSING, ETC) is given, the power supply to the control unit is taken off for 1 second and then restored to check its correct operation. If the test fails, an anomaly is signalled by some blinkings of the flashing light, see chapter 22.</p>
E 4	ENERGY SAVING	1	ENERGY SAVING EXCLUDED.
		2	<p>ENERGY SAVING ENABLED.</p> <p><b>Operation:</b> +24Vdc on terminal 32 will be present only during the operation cycle. Connecting the external accessories to this terminal, you can have a significant energy saving during the rest phase of the gate.</p> <p>With this function enabled, there will be a certain delay between the opening/closing command and the activation of the motor.</p>
E 5	INVERSION FROM PEDESTRIAN	1	<p><b>Operation :</b> During pedestrian closing, a PHOTO1 or PHOTO2 or PEDESTRIAN or START command will cause the complete opening</p>
		2	<p><b>Operation:</b> During the pedestrian closing, a PHOTO1 or PHOTO2 or PEDESTRIAN command will make open again only the pedestrian. START will cause the complete opening</p>

## UK

## 19.4 - DESCRIPTION MENU ( E )

Menu	Function	Status	Description
E 9	RESERVE INPUT (terminal 21)  management by clock, magnetic loop or different command	1	It disables the RESERVE input
		2	It enables the RESERVE input (for the connection of an external clock, a magnetic loop or a different command device) <b>Operation:</b> When the contact is on RESERVE input close, after a START command the door will open, but will not close automatically. When the contact is open, the door will close automatically after pause time. When the door is open, it is possible to enable its closing with the START command, if the STEP BY STEP or STEP BY STEP WITH STOP menu is enabled, or with CLOSING button.  WARNING: remind to enable the automatic closing
		3	It enables the RESERVE input (for the connection of an external clock, a magnetic loop or a different command) <b>Operation:</b> When the contact on the RESERVE input is close, after a START command the door will open, but will not close automatically. When the contact is open, the door will close automatically after pause time. It is not possible to enable the closing with START command and CLOSING button.  WARNING: remind to enable the automatic closing
		4	It enables the RESERVE input (for the connection of an external clock, magnetic loop or different command) <b>Operation:</b> When the contact on the RESERVE input is close, an automatic opening command will be enabled (with no need of a START command). The door will open, but will not close automatically. When the contact is open, the door will close automatically after pause time. It is not possible to enable the closing with the START command and CLOSING button. If the contact on the RESERVE input closes during closing phase, the door will open again.  WARNING: remind to enable the automatic closing

## 19.4 - DESCRIPTION MENU ( E )

Menu	Function		
E 30	ADDITIONAL ATTEMPTS to restart the motion after the intervention of the devices set as FRAME and of the MOTOR REVOLUTIONS SENSOR	 <b>WARNING!</b> A programming of the function different from the configuration preset from the manufacturer, although it allows, if correctly done, the reduction of the cases of stop of the system in intermediate position (as a simply example, for the presence of frictions, wind and/or obstacles on the way of the movable element), causes, in any case, a reduction of the safety level of the same system and a consequent danger for people safety.	
		Status	Description
		0	Any additional intervention. DEFAULT setting.
		1	After the intervention of the safety device and past the time set with H19, the automation will try to restart its motion in the direction that had been interrupted. After an additional intervention of the safety device, the automation stops waiting for a command.
		2	As set 1, but 2 attempts are made.
		3	As set 1, but 3 attempts are made.
		4	As set 1, but 4 attempts are made.
		5	As set 1, but 5 attempts are made.

## UK

## 19.4 - DESCRIPTION MENU ( E )

Menu	Function	Status	Description
E 32	REL1 management Terminals 8-9 (FREE CONTACT) Fig. 14	2	REL1 set as <b>electric lock</b> Enabled for 3 seconds at the beginning of opening and closing
		3	REL1 set as <b>courtesy light</b> Enabled for 3 minutes more after motor stop
		4	REL1 set as <b>flashing light</b> Synchronized blinking with LAMP 230V (fixed or intermittent) output
		5	REL1 set as <b>fixed light</b> Enabled for the complete opening and closing (excluded in pause)
		6	REL1 set as <b>electric magnet</b> Turned off for 3 seconds at the beginning of opening and closing
E 34	REL2 management Terminals 10-11 (FREE CONTACT) Fig. 15	2	REL2 set as <b>electric lock</b> Enabled for 3 seconds at the beginning of opening and closing
		3	REL2 set as <b>courtesy light</b> Enabled for 3 minutes more after motor stop
		4	REL2 set as <b>flashing light</b> Synchronized blinking with LAMP 230V (fixed or intermittent) output
		5	REL2 set as <b>fixed light</b> Enabled for the complete opening and closing (excluded in pause)
		6	REL2 set as <b>electric magnet</b> Turned off for 3 seconds at the beginning of opening and closing



## 19.4 - DESCRIPTION MENU ( E )

Menu	Function	Status	Description
E 36	MOTOR REOLUTIONS SENSOR (INDUCTIVE SENSOR)	1	It disables the reading of the motor revolutions sensor.
		2	It enables the reading of motor revolutions sensor.  VERY HIGH intervention sensitivity <b>Operation:</b> After a reduction of the number of revolutions of the motor (for example, obstacle) the sensor intervenes blocking the motion of the gate and inverting the movement for 2 seconds to free the obstacle. When a new Start pulse is given, the motion starts again in the direction of obstacle feeeing.  Disabled with DEAD MAN.  See also MENU E30.
		3	It enables the reading of the motorrevolutions sensor.  HIGH intervention sensitivity <b>Operation:</b> As the previous menu
		4	It enables the reading of the motor revolutions sensor.  MEDIUM intervention sensitivity <b>Operation:</b> As previous menu
		5	It enables the reading of the motor revolutions sensor.  LOW intervention sensitivity <b>Operation:</b> As previous menu
		6	Enables the reading of the motor revolutions sensor.  VERY LOW intervention sensitivity <b>Operation:</b> As previous menu

## UK

## 19.4 - DESCRIPTION MENU ( E )

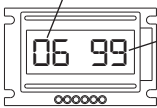
Menu	Function	Status	Description
E 40	DISPLAY OF SETTING AND INTERVENTION NUMBER OF SAFETY INPUT No.1 (TERMINAL 24)		<p>It allows to display the setting of terminal 24, defined with menu C40, and the number of safety intervention, determined by the input if set as FRAME N.C. or as FRAME 8K2.</p> <p><b>Display (example):</b></p> <p style="text-align: center;">Terminal setting from MENU C40</p>  <p>The terminal 24 is set as frame NC and has intervened 99 times (max. number).</p> <p><b>Operation:</b></p> <ul style="list-style-type: none"> <li>• With ESC you come back.</li> <li>• With OK the interventions digit blinks.</li> <li>• With + or – you set to zero the interventions number.</li> <li>•</li> </ul> <p>Warning: AT EVERY NEW SETTING OF THE INPUT THE INTERVENTIONS NUMBER IS SET TO ZERO.</p>
E 41	DISPLAY OF SETTING AND INTERVENTIONS NUMBER OF SAFETY INPUT No.2 (TERMINAL 25)		<p>It allows to display the setting of terminal 25, defined with menu C41, and the number of safety interventions, determined by the input if set as FRAME N.C. or as FRAME 8K2.</p> <p><b>Operation:</b> See E40</p>
E 42	DISPLAY OF SETTING AND INTERVENTIONS NUMBER OF SAFETY INPUT No.3 (TERMINAL 26)		<p>It allows to display the setting of terminal 26, defined with menu C42, and the number of safety interventions, determined by the input, if set as FRAME N.C. or as FRAME 8K2.</p> <p><b>Operation:</b> See E40</p>

## 19.4 - DESCRIPTION MENU ( E )

Menu	Function	Status	Description
E 43	DISPLAY OF SETTING AND INTERVENTIONS NUMBER OF SAFETY INPUT No.4 (TERMINAL 27)		It allows to display the setting of terminal 27, defined with menu C43, and the number of safety interventions, determined by the input if set as FRAME N.C. or as FRAME 8K2. <b>Operation:</b> Vedi E40
E 44	DISPLAY OF SETTING AND INTERVENTIONS NUMBER OF SAFETY INPUT No.5 (TERMINAL 28)		It allows to display the setting of terminal 28, defined with menu C44, and the number of safety interventions, determined by the input if set as FRAME N.C. or as FRAME 8K2. <b>Operation:</b> See E40
E 90	NUMBER OF MAINTENANCE CICLES		It allows to set a number of cycles (opening + closing) before the request for maintenance. The set value is always multiplied by 10. If 0000 is set, the numbering is excluded. When the number of cycles set is reached, the maintenance request will be signalled by a slow blinking of 60 sec. at the end of the manoeuvre.  WARNING: Each time you enter in menu E90 (WITH BLINKING NUMBERS, THAT MEANS READY TO BE MODIFIED), the counting of the cycles number is set to zero starting from the beginning.
E 92	PASSWORD		It allows to customize the PASSWORD to accede to the programming of the control unit, see chapter 7. Only if you know the PASSWORD, you can accede to the programming.
E 94	FIRMWARE VERSION		It shows the firmware version installed on the control unit. (XX__YY)
E 96	NUMBER OF CYCLES DONE		Number of manoeuvres done. The value displaied is increased every 10 manoeuvres.
E 98	NUMBER OF POWER SUPPLY DAYS		Number of days of control unit power supply. This data is increased when 24 hours are past. Possible lacks of power supply set to zero the counting of last day.

## UK

## 20 - SYNCHRONISM

By the terminal M11 it is possible to synchronize two control units, see figure 35.

**Connections:**

- Connect only one button START to one of the two control units.
- Connect the photocell 1 to terminal 24 of one of the two control units. The command, by terminal M11, will be extended also to the other control unit.
- The radio plug-in receiver (if provided) can be connected to one of the two control units;
- Connect possible devices more one by one on the control units as you would make on two separate systems.

**Terminals legend :**

S1 = start  
 S2 = photo 1  
 S3 = synchronism opens  
 S4 = common

In this application each control unit can be commanded one by one with OPEN, CLOSE and PEDESTRIAN command.

The START command (external control panel or radio receiver) will enable both control unit.

To avoid any not synchronized movement, it is necessary to set :

- Menu A3 = 4 (CONDOMINIUM LOGIC).
- Menu C3 ( PREFLASHING ): the same on both control units.
- If there are some photocells, menu C40=3 (terminal 24 set as PHOTOCCELL 1) and connect them to terminal 24.
- Menu C10 (HAMMER STROKE ): the same on both control units.
- Menu E1 (TEST PHOTOCCELL 1): the same on both control units.
- Menu E3 (TEST SAFETY DEVICES): the same on both control units.
- Menu E9 (RESERVE INPUT:, the same on both control units and parallel connections on both control units.
- Menu H9: the same on both control units. The first central that starts the closing commands also the other one.

**WARNING:**

In case of intervention of safety devices (FRAME, STOP, PHOTOCCELL 2 or MOTOR REVOLUTIONS SENSOR), each control unit will be enabled one by one. They will be synchronized again at next manoeuvre.

## 21 - PEDESTRIAN MANOEUVRE

The pedestrian manoeuvre is made after the closing of PEDESTRIAN contact (terminal 16) or by relay 2 of the two channels plug-in receivers.

### Operation in reply to PEDESTRIAN command:

- Close gate → OPEN for the time set on menu H10 and till the opening limit switch max.
- During opening → IRRELEVANT
- Open gate → IRRELEVANT if the pedestrian automatic reclosing is enabled, otherwise CLOSES
- During closing → With menu E5=2 OPEN for the time set on menu H10 and till the opening limit switch max.  
With menu E5=1 OPEN completely.

## 22 - FLASHING LIGHT SIGNALLINGS SUMMARY

Device	Signalling	Effect
Photo 2 intercepted at rest in presence of START command	5 fast flashings	When released, it opens
Frame intercepted at rest in presence of START command	3 slow flashings	Door blocked close
Frame intercepted in pause in presence of START command at the beginning of closing	3 slow flashings	Door blocked open
Test photo 1 failed at the beginning of closing	4 fast flashings	Door blocked open
Test photo 2 failed at the beginning of opening	3 fast flashings	Door blocked close
Test photo 2 failed at the beginning of closing	3 fast flashings	Door blocked open
Test frame N.C. failed at the beginning of opening	3 slow flashings	Door blocked close
Test frame N.C. failed at the beginning of closing	3 slow flashings	Door blocked open
Test frame 8K2 failed at the beginning of opening	2 slow flashings	Door blocked close
Test frame 8K2 failed at the beginning of closure	2 slow flashings	Door blocked open
Expired maintenance	1 minute of slow flashing with close door	Any

## UK

## 23 - FINAL CHECKING

- Check the electrical connections: a wrong connection may damage both the control unit and the operator.
- Check the correct position of the limit switches (MENU C23).
- Always preset the mechanical stops in opening and closing.
- Check the correct operation of photocells and safety devices.
- Check that the motors are blocked and ready to work with GATE AT HALFWAY POSITION.
- Remove possible obstacles in the operating area of the gate.
- Check that the direction of gate motion is correct:
  - take off the power supply from the control unit.
  - power the control unit.
  - give a START command.
  - check that the gate is opening, otherwise take off the power supply from the control unit and invert the wires of terminal M2
- Check the correct operation of the automation.

## DISPOSAL

Gi.Bi.Di. advises recycling the plastic components and disposing of them, at special authorized centres, for electronic components, protecting the environment from polluting substances.



## CE Declaration of conformity

The manufacturer:

**GI.BI.DI. S.r.l.**

Via Abetone Brennero, 177/B,  
46025 Poggio Rusco (MN) ITALY

Declares that the products:

**ELECTRONIC CONTROL UNIT SC380**

Are in conformity with the following CEE Directives:

- **LVD Directive 2006/95/CE and subsequent amendments;**
- **EMC Directive 2004/108/CE and subsequent amendments;**

and that the following harmonized standards have been applied:

- **EN60335-1, EN60335-2-103, EN50366**
- **EN61000-6-2, EN61000-6-3**

Date 10/11/2013

The legal Representative

Michele Prandi



# GIBIDI

**GI.BI.DI. S.r.l.**

Via Abetone Brennero, 177/B  
46025 Poggio Rusco (MN) - ITALY  
Tel. +39.0386.52.20.11  
Fax +39.0386.52.20.31  
E-mail: [comm@gibidi.com](mailto:comm@gibidi.com)

Numero Verde: 800.290156

[www.gibidi.com](http://www.gibidi.com)

