

G:B:D:

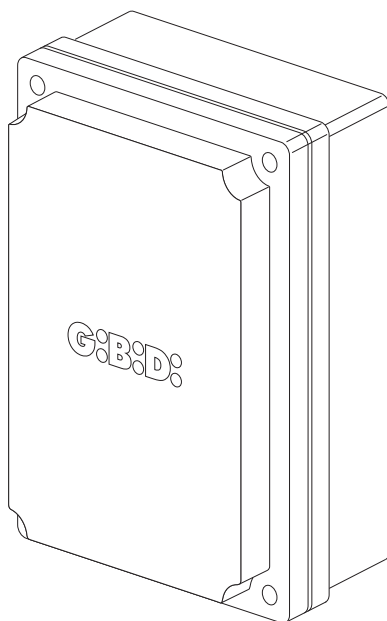

:BR24

CE

BR24 - (AS05560)

Apparecchiatura elettronica
SCHEMI E DISEGNI PER L'INSTALLAZIONE

Electronic control unit
DIAGRAMS AND DRAWINGS FOR INSTALLATION

SCHEMA ELETTICO / ELECTRICAL CONNECTION

1

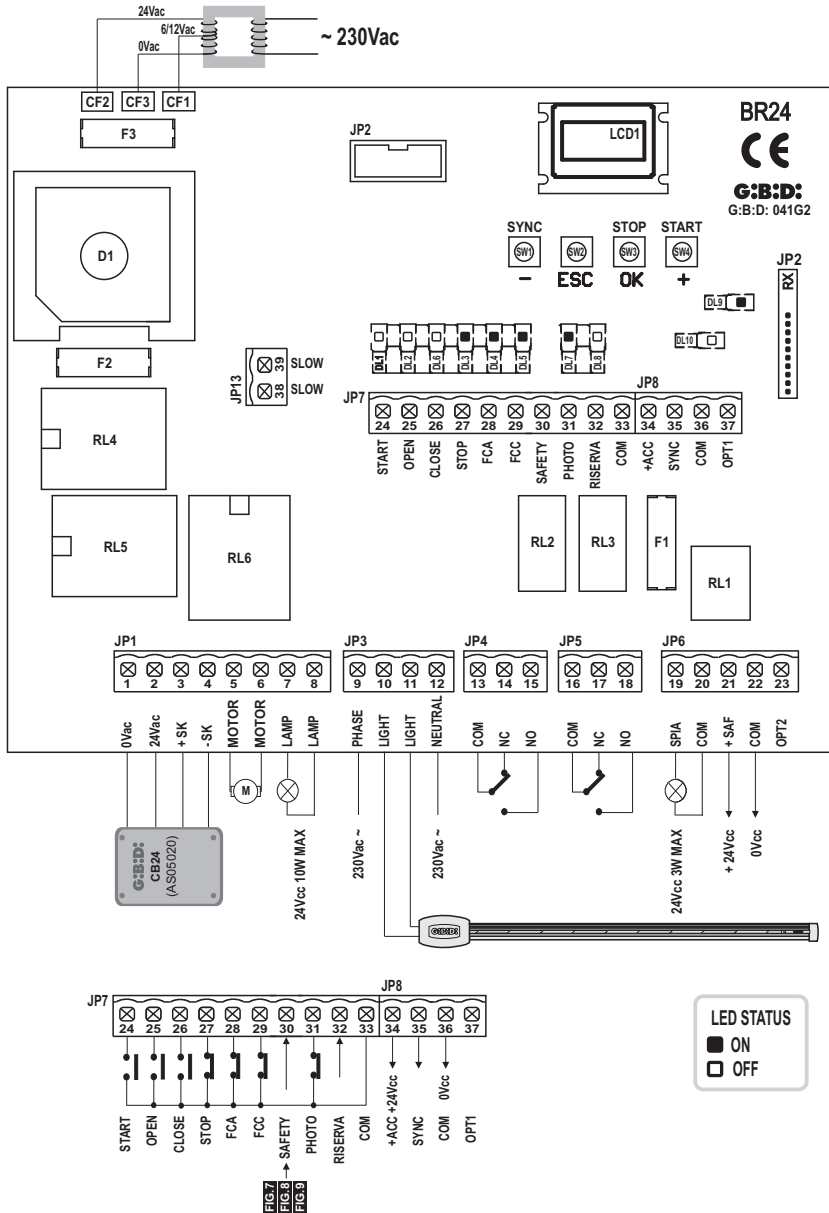

SINCRONISMO / SYNCHRONISM

2

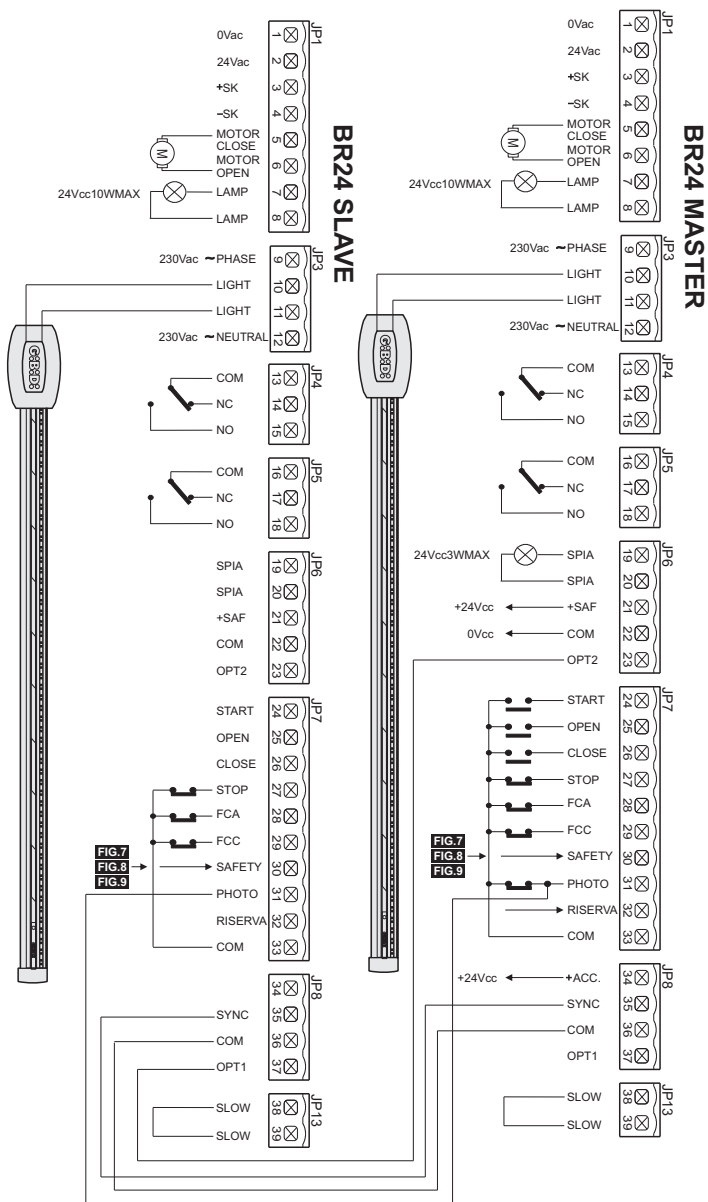

COLLEGAMENTO BATTERIE CON SINCRONISMO / BATTERY BACKUP CONNECTION WITH SYNCRONISM

3

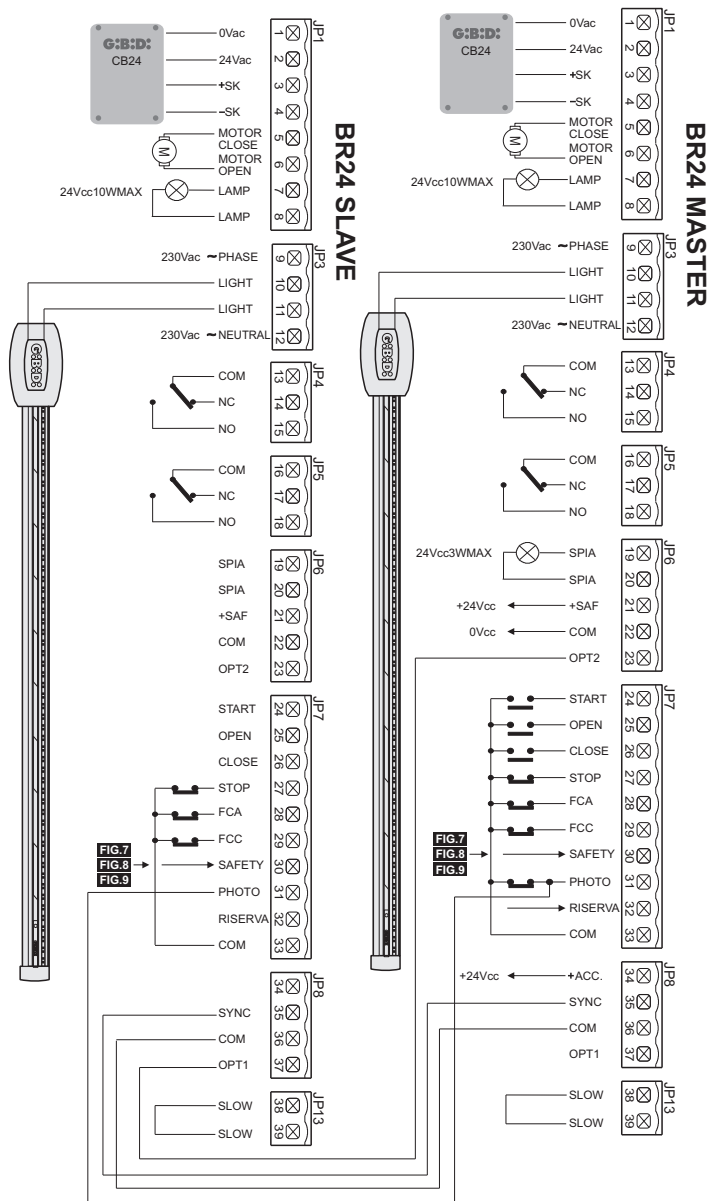

OROLOGIO ESTERNO / EXTERNAL CLOCK

4

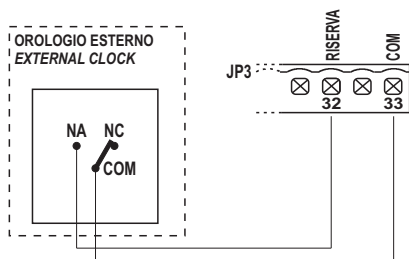

SEMAFORO UNA VIA / ONE WAY TRAFFIC LIGHT

5

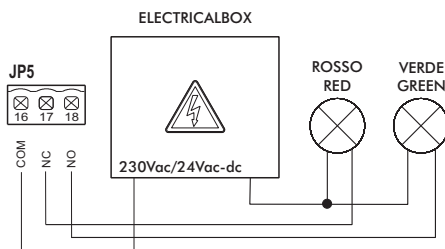

SEMAFORO DUE VIE / TWO WAYS TRAFFIC LIGHT

6

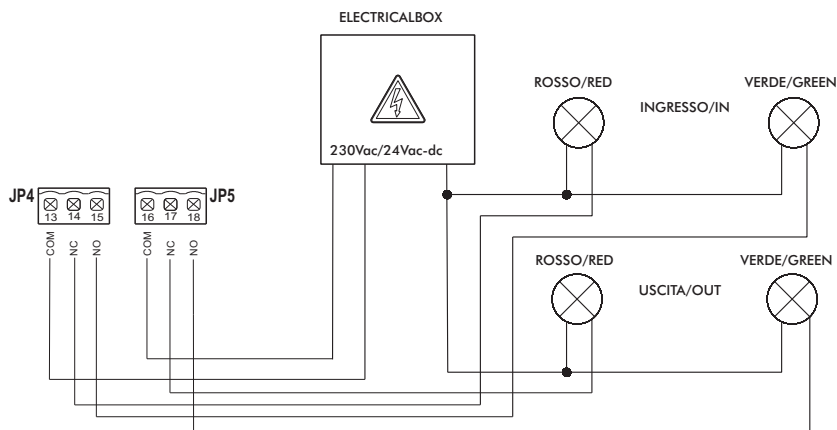

COLLEGAMENTO COSTA / SAFETY DEVICE CONNECTION

7

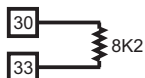

SENZA BORDO SENSIBILE
WITHOUT CONDUCTIVE EDGE

8



BORDO SENSIBILE CON RESISTENZA 8K2 INTEGRATA
CONDUCTIVE EDGE WITH RESISTANCE 8K2 INTEGRATED

9

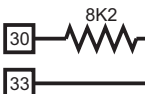

BORDO SENSIBILE CON CONTATTO N.C.
CONDUCTIVE EDGE WITH N.C. CONTACT

COLLEGAMENTO FOTOCELLULE / PHOTOCELLS CONNECTION

10

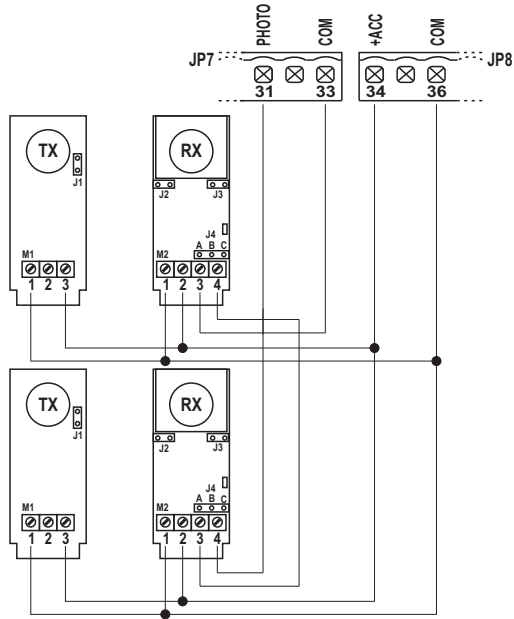

11



FOTO TEST / PHOTO TEST

12



13

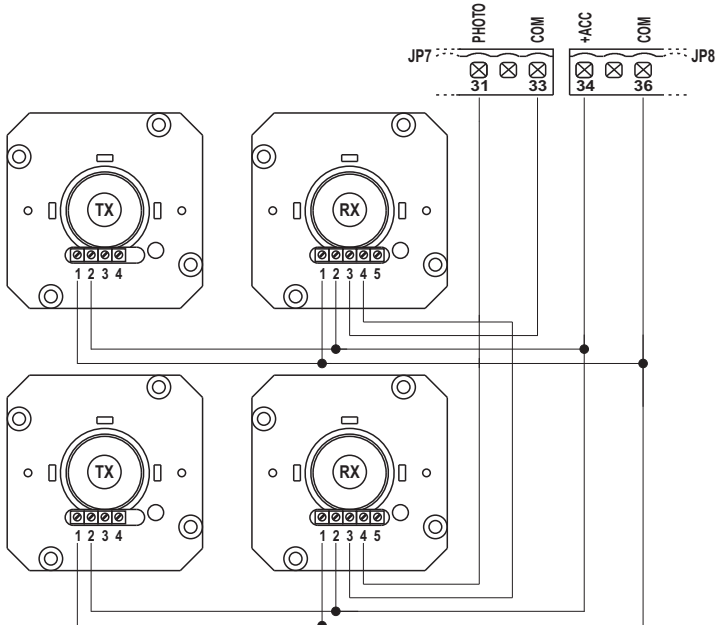
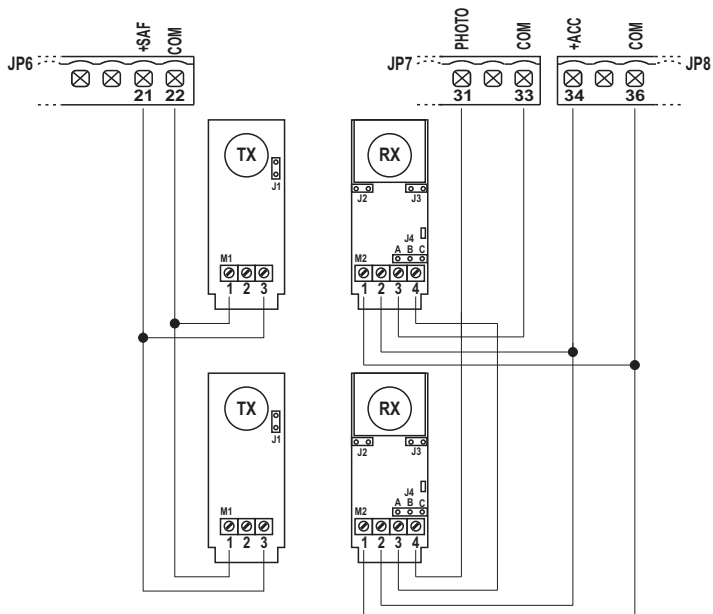
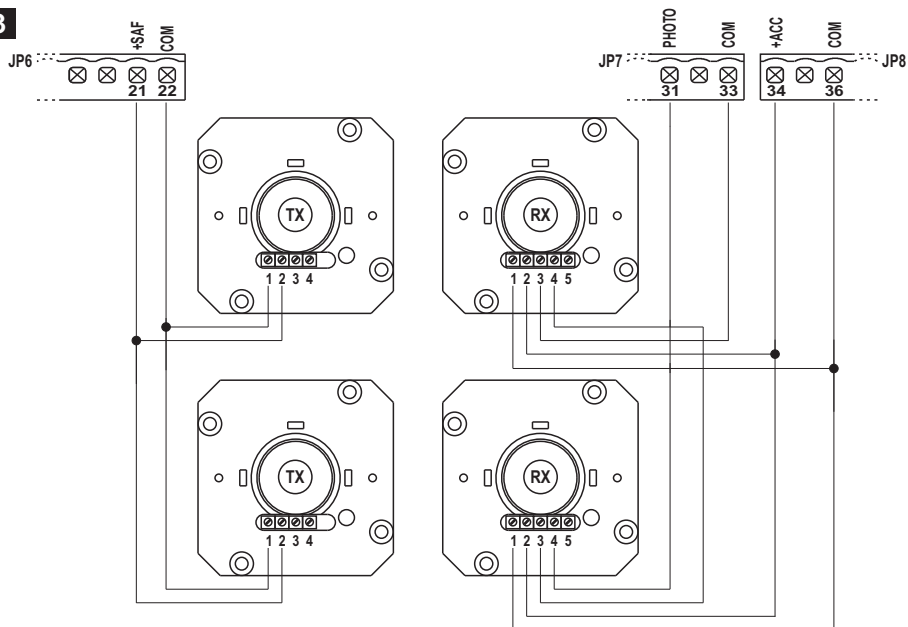

GIBIDI

G.I.B.I.D.I. S.r.l.

Via Abetone Brennero, 177/B
46025 Poggio Rusco (MN) - ITALY
Tel. +39.0386.52.20.11
Fax +39.0386.52.20.31
E-mail: comm@gibidi.com

Numero Verde: 800.290156

www.gibidi.com

