

G:B:D:

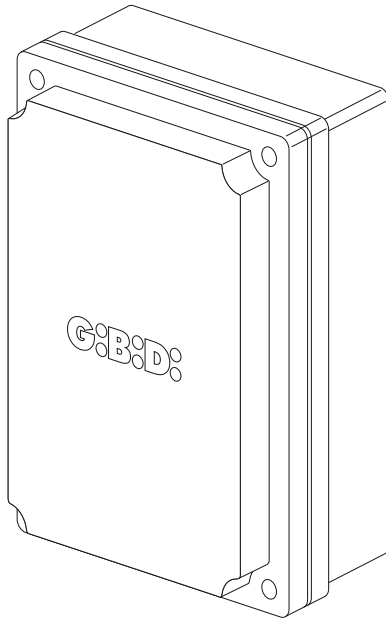

:BE24

**CE UK
CA**

BE24 (AS06250)

Apparechiatura elettronica
SCHEMA ELETTRICO E COLLEGAMENTI

Electronic control unit
ELECTRICAL CONNECTIONS

I UK

I-UK

SCHEMA ELETTRICO / ELECTRICAL CONNECTIONS

1

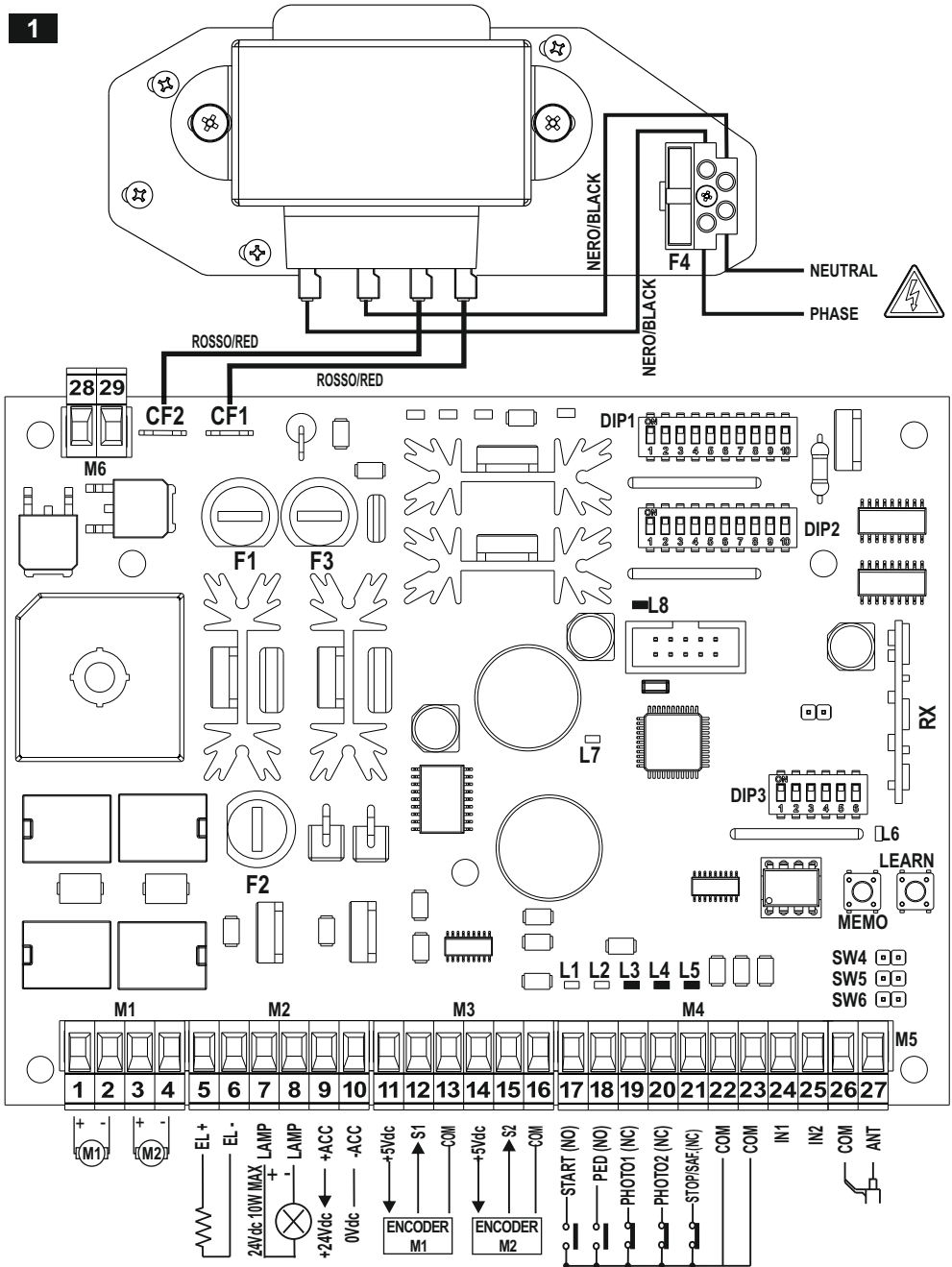

COLLEGAMENTO MOTORE / MOTOR CONNECTION

2

KUDA CON ENCODER / KUDA WITH ENCODER



DIP2_4 = ON

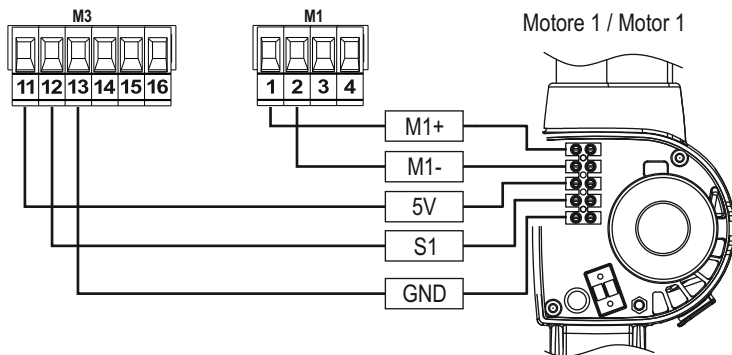

Motore 2 / Motor 2

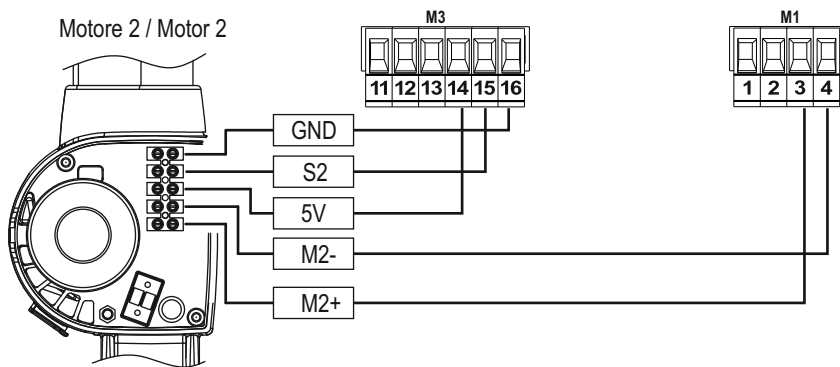

KUDA SENZA ENCODER / KUDA WITHOUT ENCODER



DIP2_4 = OFF

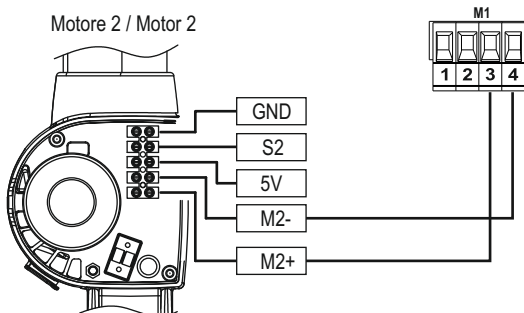
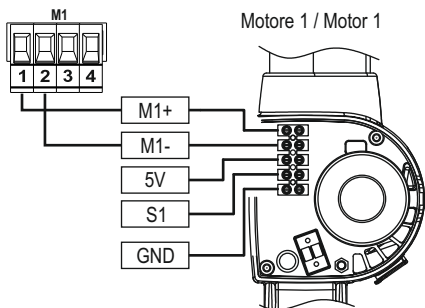

I-UK

COLLEGAMENTO MOTORE / MOTOR CONNECTION

2A

SERRA320 CON ENCODER / SERRA320 WITH ENCODER

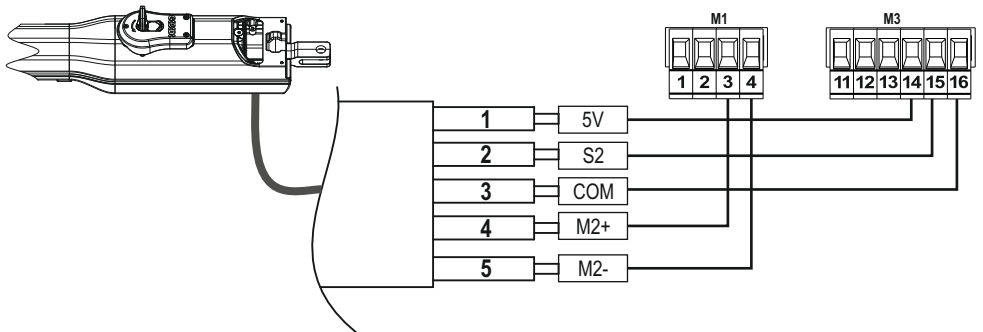
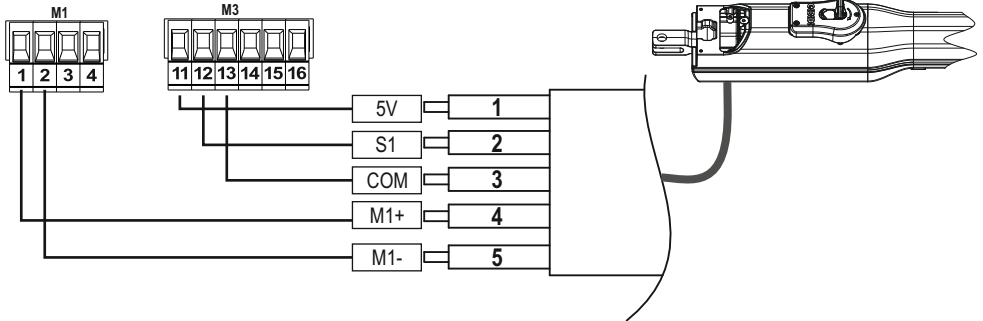
 ON
 OFF 4
 DIP₂_4 = ON

SERRA320 SENZA ENCODER / SERRA320 WITHOUT ENCODER

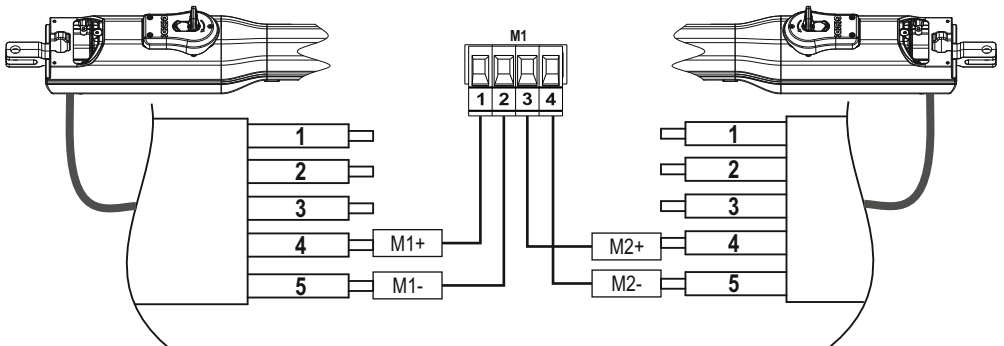
 ON
 OFF 4
 DIP₂_4 = OFF

I-UK

COLLEGAMENTO MOTORE / MOTOR CONNECTION

AGO CON ENCODER / AGO WITH ENCODER



DIP2_4 = ON

2B

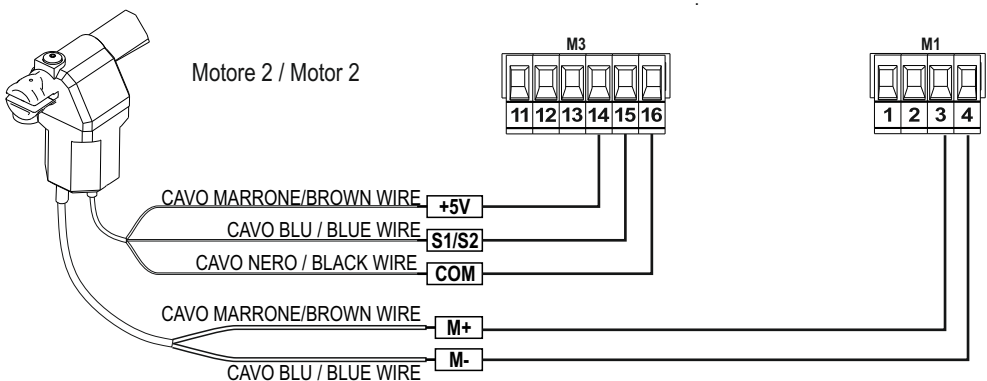
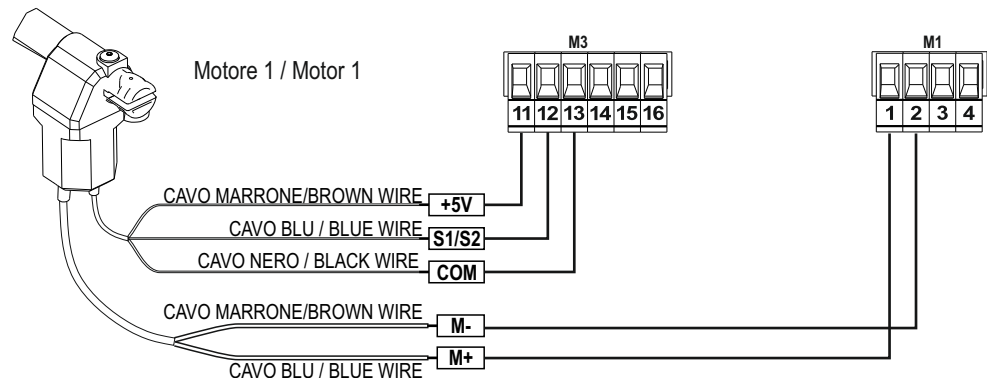

AGO SENZA ENCODER / AGO WITHOUT ENCODER



DIP2_4 = OFF

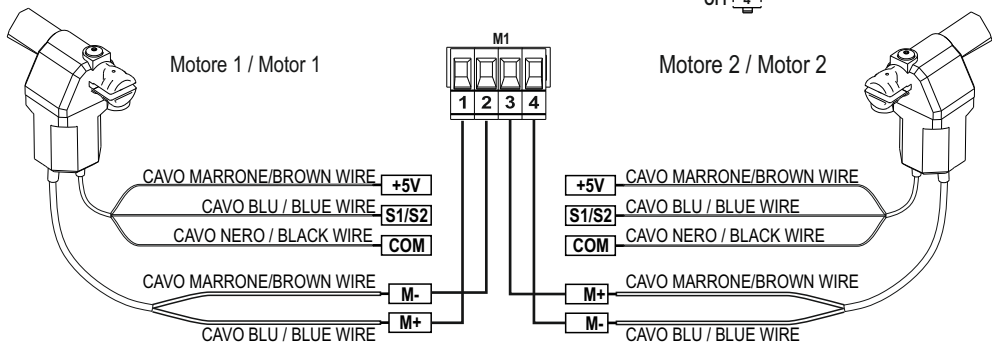

I-UK

COLLEGAMENTO MOTORE / MOTOR CONNECTION

2C

SNAPPER CON ENCODER / SNAPPER WITH ENCODER

LEFT OPERATOR-MOTOR 1
OPERATORE SINISTRO-MOTORE 1

RIGHT OPERATOR-MOTOR 2
OPERATORE DESTRO-MOTORE 2

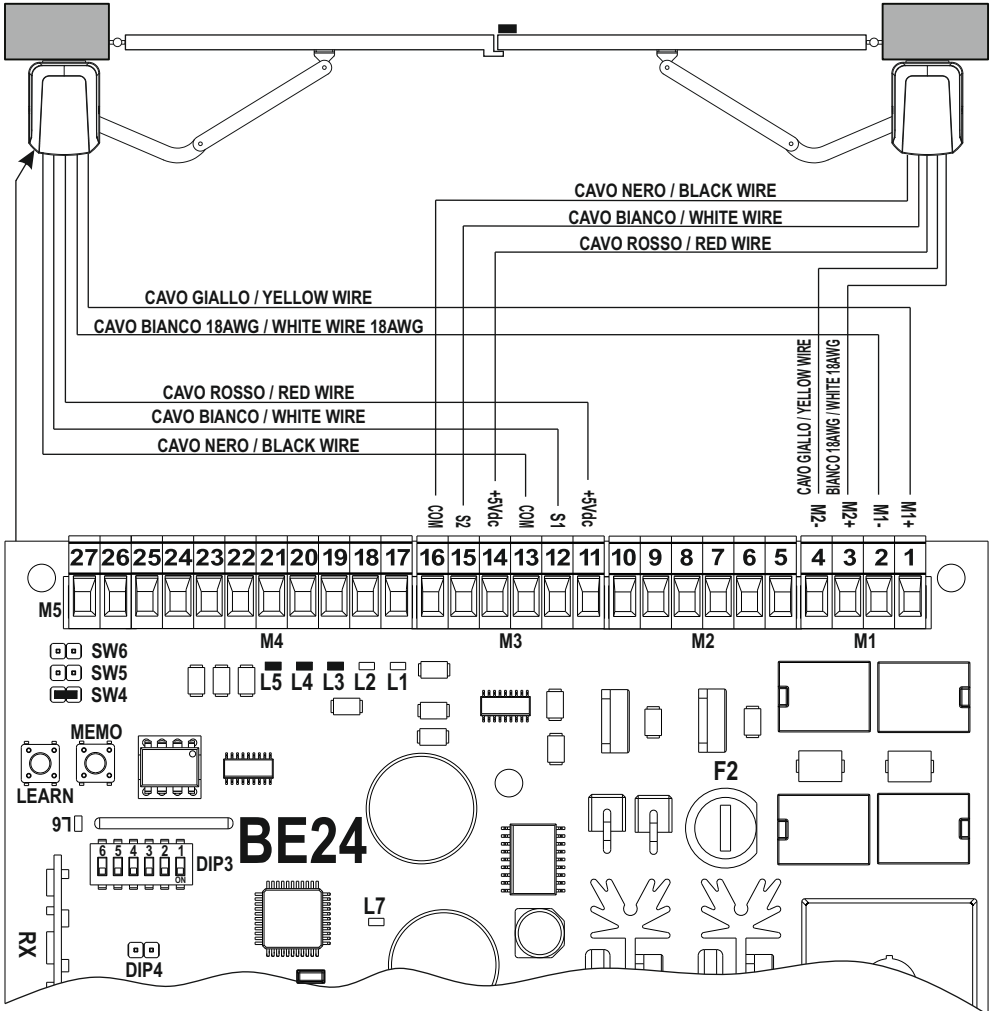

I-UK

COLLEGAMENTO MOTORE / MOTOR CONNECTION

SNAPPER SENZA ENCODER / SNAPPER WITHOUT ENCODER

2D

LEFT OPERATOR-MOTOR 1
OPERATORE SINISTRO-MOTORE 1

RIGHT OPERATOR-MOTOR 2
OPERATORE DESTRO-MOTORE 2

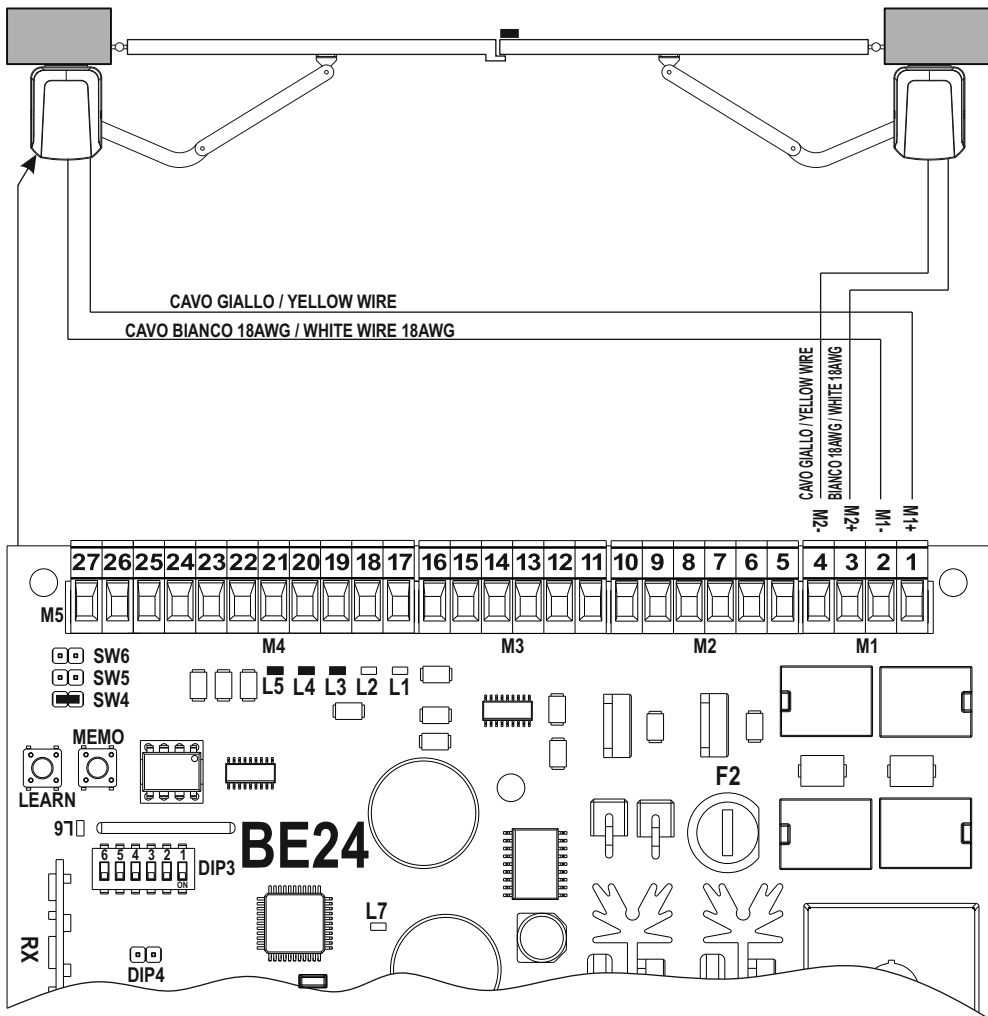

I-UK

COLLEGAMENTO ELETTROSERRATURA / ELECTRICAL LOCK CONNECTION

3

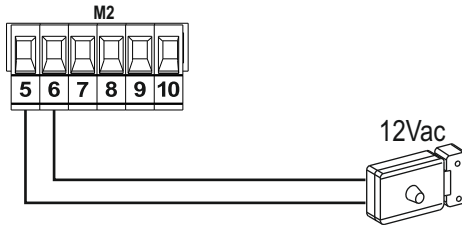

COLLEGAMENTO LAMPEGGIANTE / FLASHING LIGHT CONNECTION

4

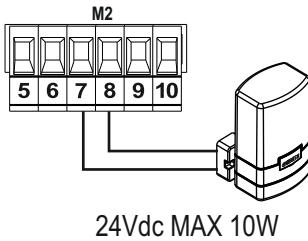

DIP2_6 = OFF



COLLEGAMENTO SPIA DI SEGNALAZIONE / WARNING LIGHT CONNECTION

4A

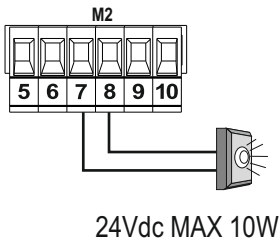

DIP2_6 = ON



COLLEGAMENTO DISPOSITIVI DI COMANDO / CONTROL DEVICES CONNECTION

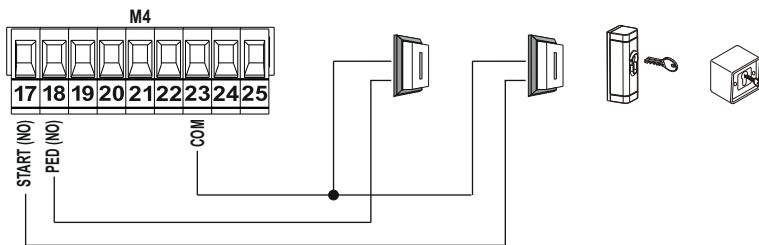

5

COLLEGAMENTO FOTOCELLULE 1 / PHOTOCELLS 1 CONNECTION

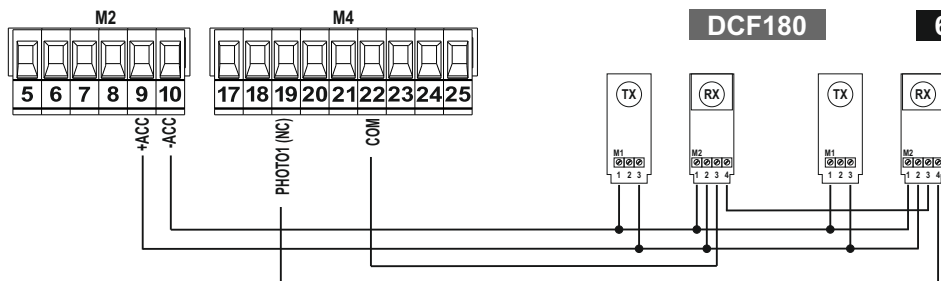

DCF180

6

COLLEGAMENTO FOTOCELLULE 2 / PHOTOCELLS 2 CONNECTION

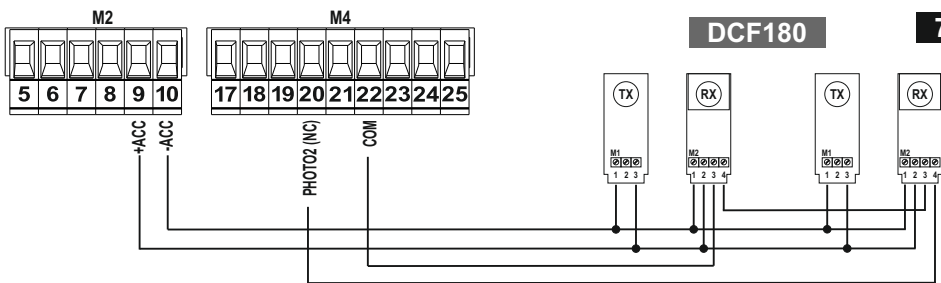

DCF180

7

COLLEGAMENTO FOTOCELLULE 1 / PHOTOCELLS 1 CONNECTION

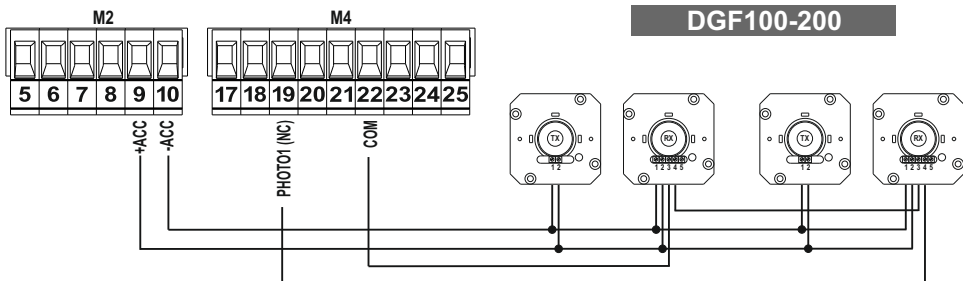

DGF100-200

8

CONSULTARE IL MANUALE DELLE FOTOCELLULE PER MAGGIORI DETTAGLI / REFER TO THE PHOTOCELLS MANUAL FOR DETAILED CONNECTION DIAGRAMS

I-UK

COLLEGAMENTO FOTOCELLULE 2 / PHOTOCELLS 2 CONNECTION

9

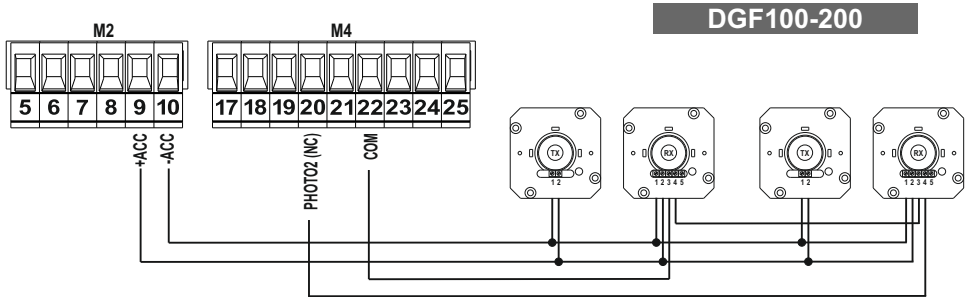

COLLEGAMENTO "DISPOSITIVO DI SICUREZZA" 8K2 / 8K2 "SAFETY DEVICE" CONNECTION

10



DIP1_2 = ON

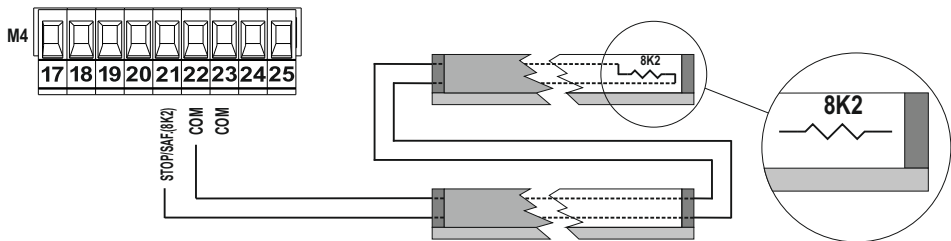
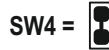

COLLEGAMENTO "DISPOSITIVO DI SICUREZZA" NC / NC "SAFETY DEVICE" CONNECTION

11

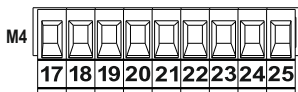

DIP1_2 = ON

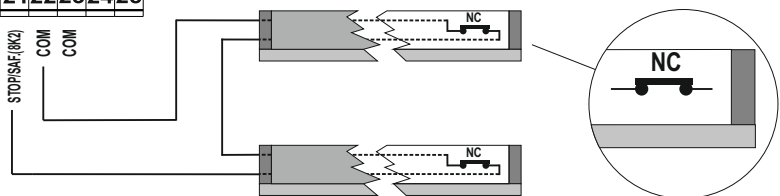
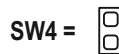

I-UK

COLLEGAMENTO STOP N.C. / N.C. STOP CONNECTION

12

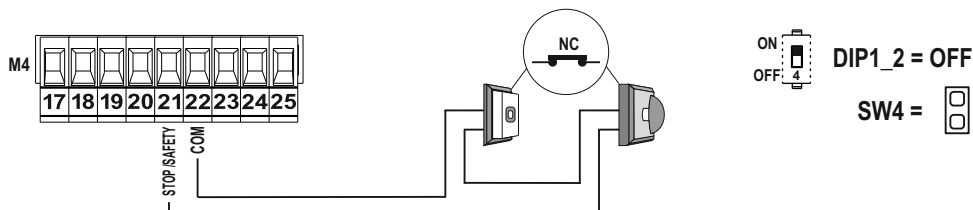

COLLEGAMENTO STOP 8K2 / 8K2 STOP CONNECTION

13

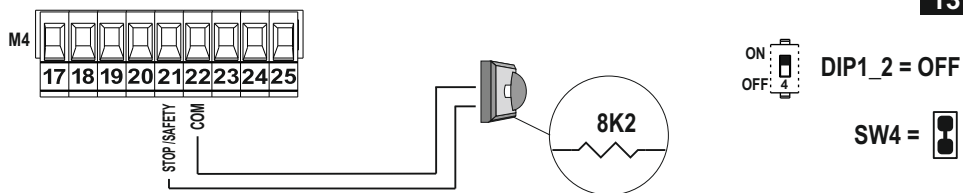

IMPOSTAZIONE DI DEFAULT DIP1 / DIP1 DEFAULT SETTINGS

14

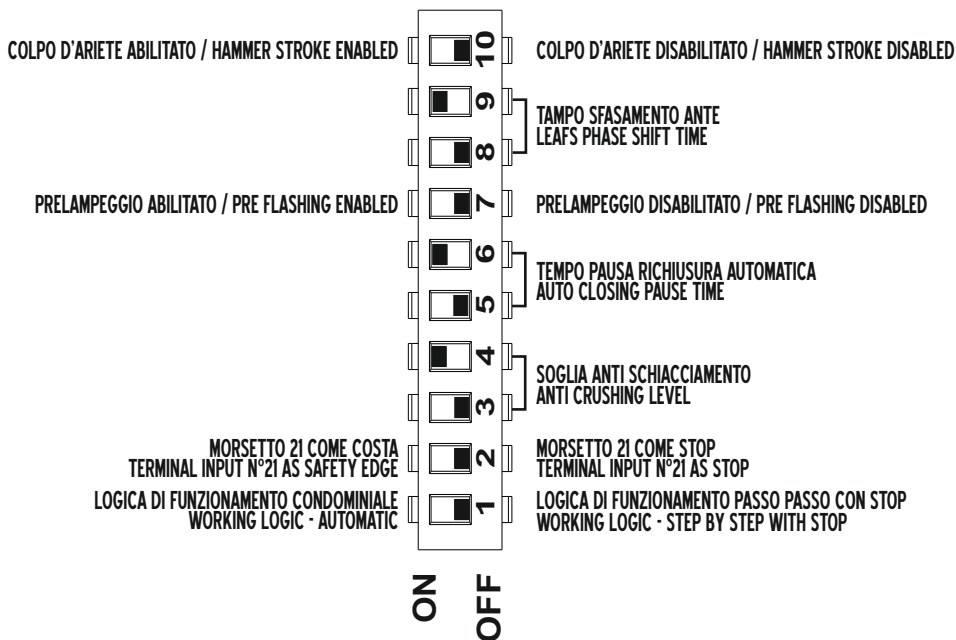

I-UK

IMPOSTAZIONE DI DEFAULT DIP2 / DIP2 DEFAULT SETTINGS

15

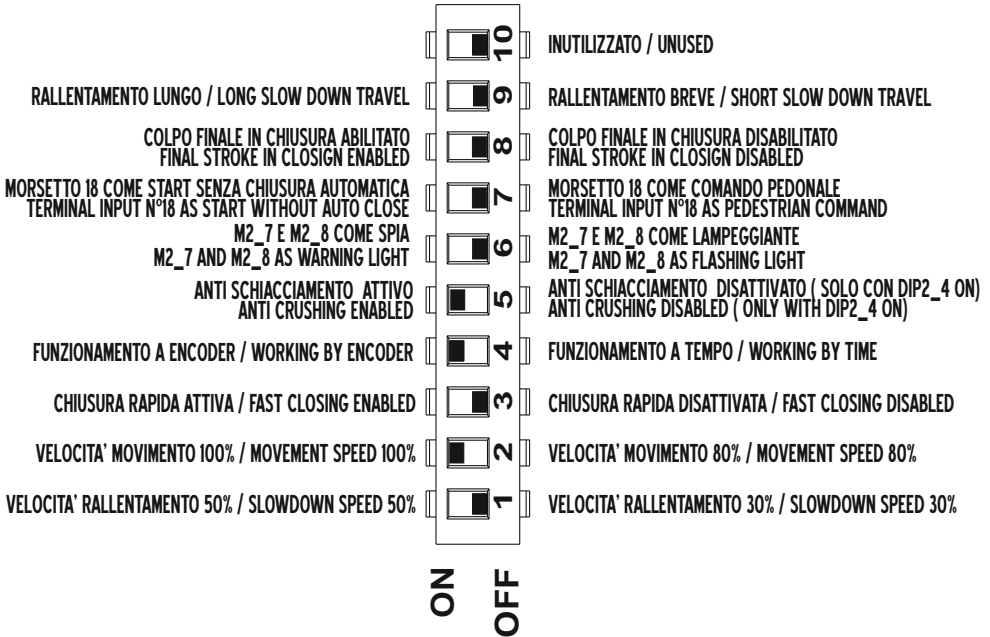

IMPOSTAZIONE DI DEFAULT DIP3 / DIP3 DEFAULT SETTINGS

16

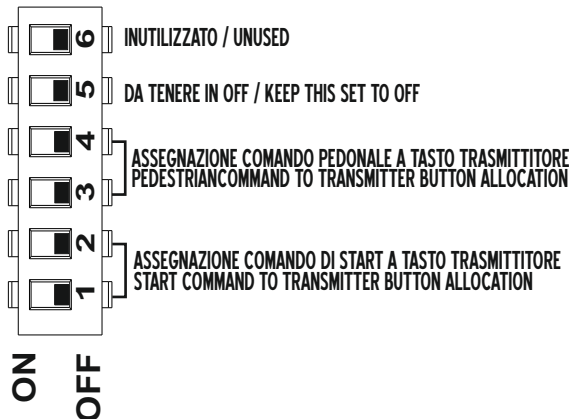

IMPOSTAZIONE DIP3_1 E DIP3_2 / DIP3_1 AND DIP3_2 SETTINGS

17

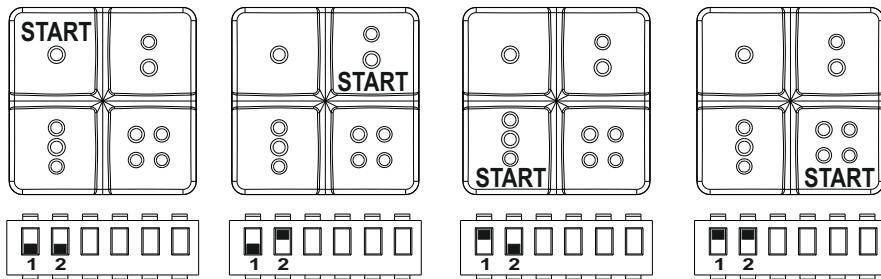

IMPOSTAZIONE DIP3_3 E DIP3_4 / DIP3_3 AND DIP3_4 SETTINGS

18

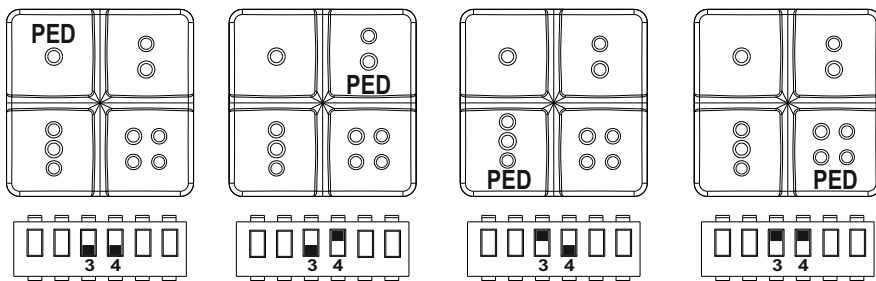

KIT BATTERIE DI BACKUP ESTERNO / EXTERNAL BATTERY BACKUP KIT

19

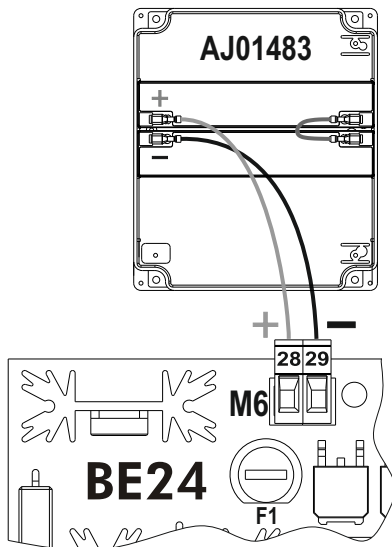

I-UK

KIT BATTERIE DI BACKUP SNAPPER / SNAPPER EXTERNAL BATTERY BACKUP

20

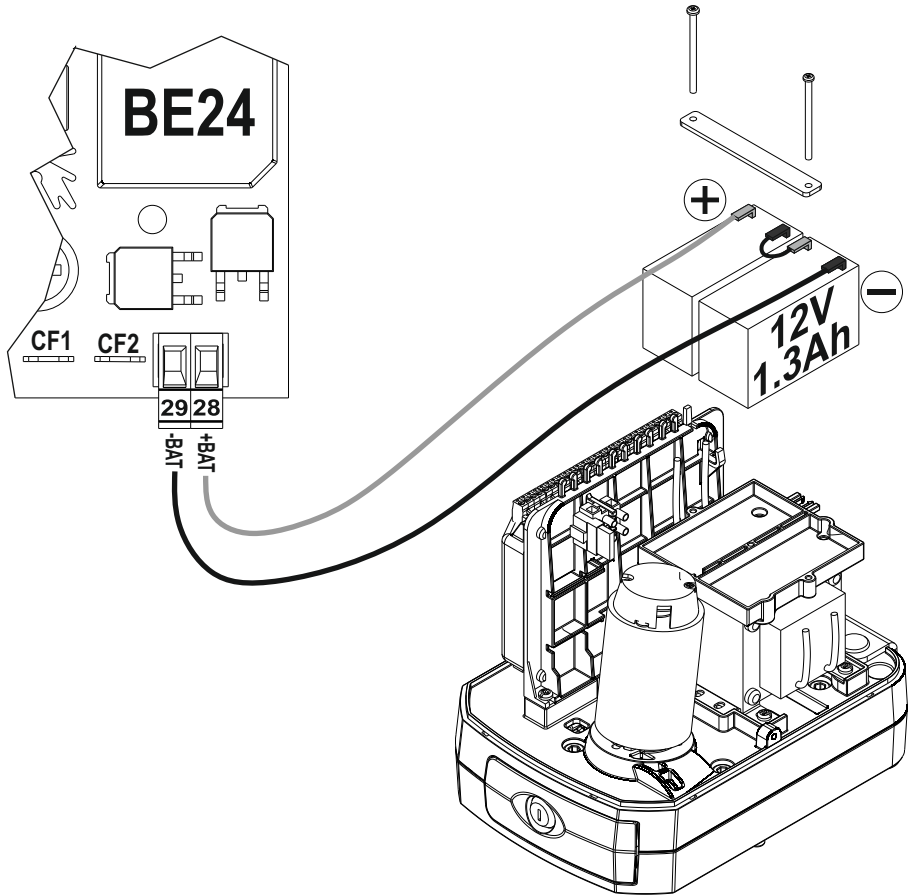

GIBIDI

G.I.B.I.D.I. S.r.l.

Via Abetone Brennero, 177/B
46025 Poggio Rusco (MN) - ITALY
Tel. +39.0386.52.20.11
Fax +39.0386.52.20.31
E-mail: info@gibidi.com

Numero Verde: 800.290156

www.gibidi.com

