



ENGLISH - LED traffic light with two lights - power min 90 V ac max 265 V ac

ITALIANO - Semaforo a LED a due luci - power min 90 V ac max 265 V ac

DEUTSCH - Ampel mit zwei LED lichten - power min 90 V ac max 265 V ac

ESPAÑOL - Semáforo con LED con dos luces - power min 90 V ac max 265 V ac

FRANCAIS - Feux à LED avec deux lumières - power min 90 V ac max 265 V ac



Instruction - Istruzioni - Anleitungen - Instrucciones

(EN) TECHNICAL DATA SHEET

Power supply: **min 90 V ac max 265 V ac**

Weight: **1,95 Kg**

Lens color: **Red, Green, Yellow**

Lamp consume: **3 w**

Middle life lamp: **100.000 hours**

Degree of protection: **IP 65**

(IT) CARATTERISTICHE TECHICHE

Alimentazione elettrica: **min 90 V ac max 265 V ac**

Peso: **1,95 Kg**

Colore lenti: **Rosso, Verde, Giallo**

Consumo lampada: **3 w**

Durata media lampada: **100.000 ore**

Grado di protezione: **IP 65**

(DE) TECHNISCHE EIGENSCHAFTEN

Elektrische Ernährung: **min 90 V ac max 265 V ac**

Gewicht: **1,95 Kg**

Farbe langsam: **Rot, Grün, Gelb**

Verbrauche Lampe: **3 w**

Leben vermittelt Lampe: **100.000 Stunden**

Maß an Schutz: **IP 65**

(FR) CARACTERISTIQUES TECHNIQUES

Alimentation électrique: **min 90 V ac max 265 V ac**

Poids: **1,95 Kg**

Couleur verres: **Rouge, Vert, Jaune**

Consommation lampe: **3 w**

Durée moyenne lampe: **100.000 heures**

Degré de protection: **IP 65**

(ES) CARACTERÍSTICAS TÉCNICAS

Alimentación eléctrica: **min 90 V ac max 265 V ac**

Peso: **1,95 Kg**

Color lente: **Rojo, Verde, Amarillo**

Consumo lámpara: **3 w**

Vida mediana lámpara: **100.000 horas**

Grado de protección: **IP 65**

H.T.C. GROUP SRL

Via Milano, 8 - 20816 Ceriano Laghetto (MB)

Tel +39 02 96460902 Fax +39 02 96468606

(EN) DIMENSIONS
(IT) DIMENSIONI
(DE) DIMENSIONEN
(FR) DIMENSIONS
(ES) DIMENSIONES

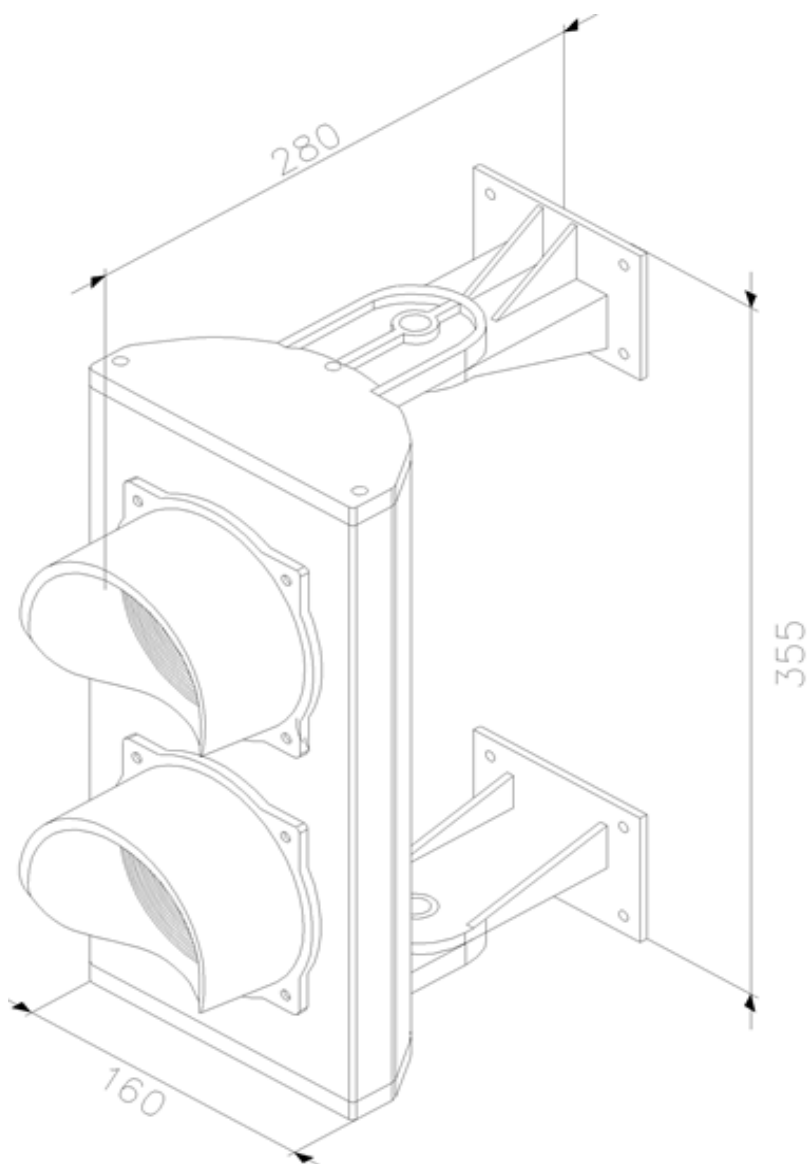

H.T.C. GROUP SRL

Via Milano, 8 - 20816 Ceriano Laghetto (MB)
Tel +39 02 96460902 Fax +39 02 96468606

SCHEMA DI ASSEMBLAGGIO SCHEDULE OF ASSEMBLY

Rif.	CODE CEPLA
1	MSO10119
2	PSO10061
3	PSO10062
4	PSO10063
5	MSO10136
7	MSO10120
8.1	PSO10065 (RED)
8.2	PSO10066 (GREEN)
8.3	PSO10067 (ORANGE)
9	MSO10121
10	PSO10064
11	MSO10122
12	MSO10123

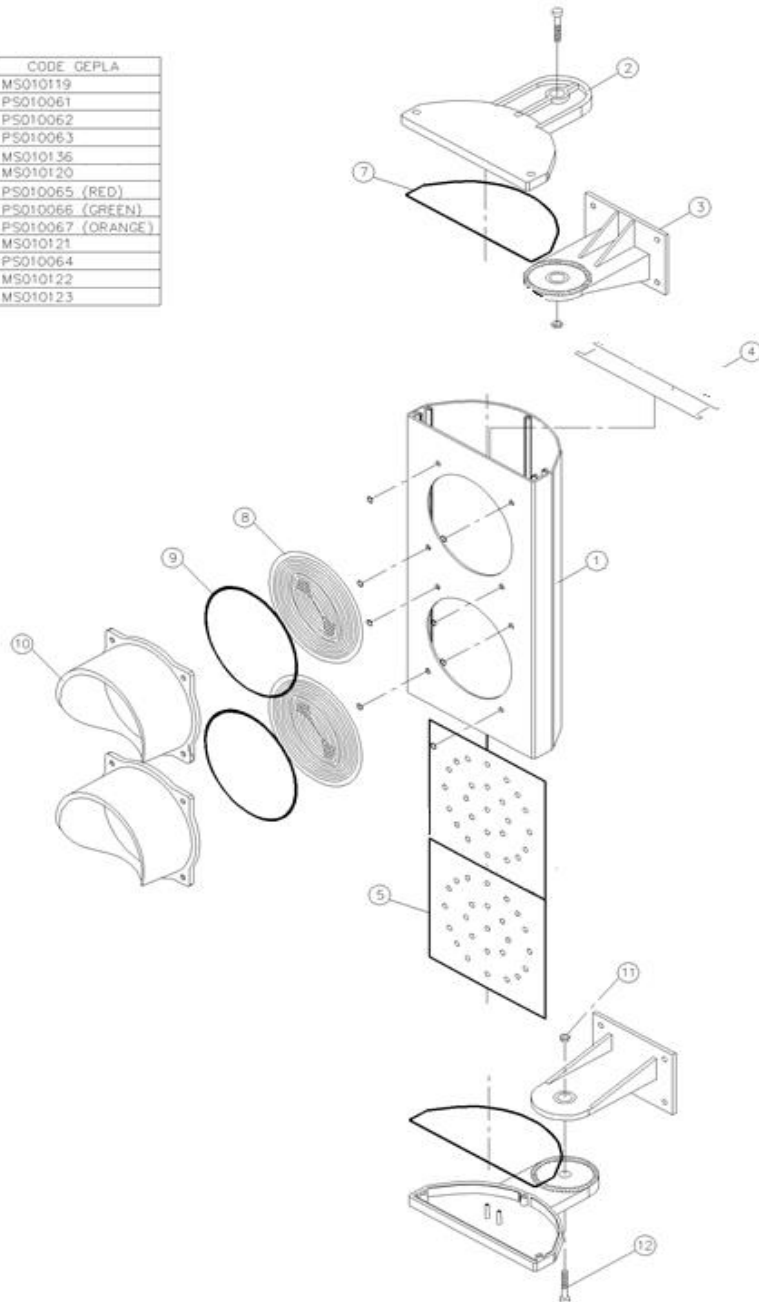

H.T.C. GROUP SRL

Via Milano, 8 - 20816 Ceriano Laghetto (MB)

Tel +39 02 96460902 Fax +39 02 96468606

SCHEMA ELETTRICO ELECTRICAL DIAGRAM

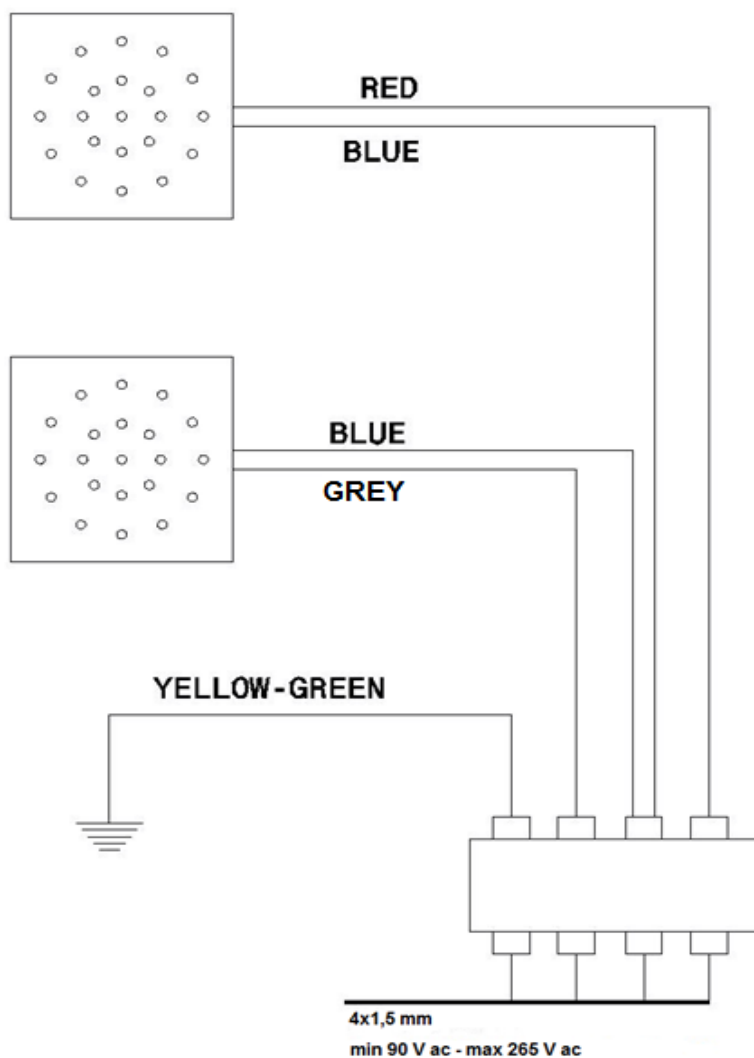

H.T.C. GROUP SRL

Via Milano, 8 - 20816 Ceriano Laghetto (MB)

Tel +39 02 96460902 Fax +39 02 96468606

(EN) ASSEMBLY POSITIONS
(IT) POSIZIONI DI MONTAGGIO
(DE) POSITIONIERST VON MONTAGE
(FR) POSITIONS D'ASSEMBLAGE
(ES) POSICIONES DE MONTAJE

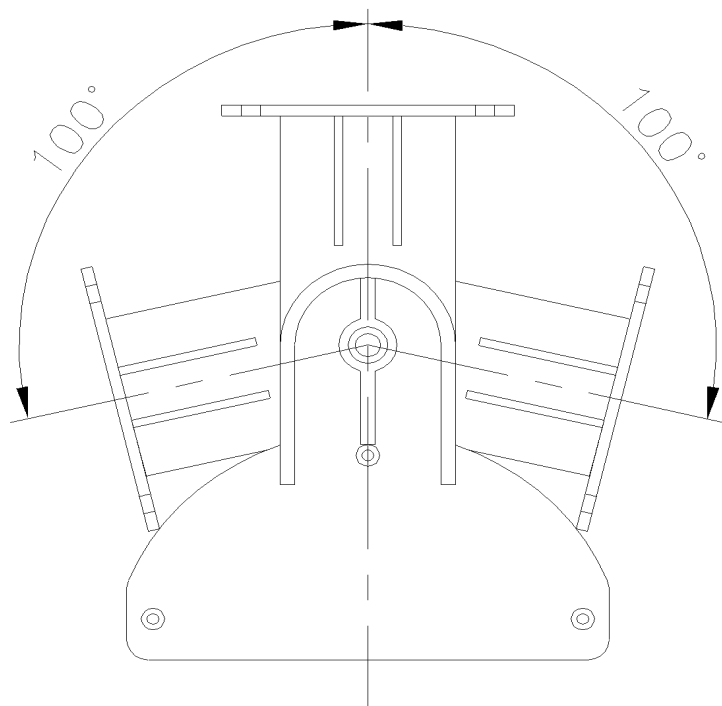

H.T.C. GROUP SRL

Via Milano, 8 - 20816 Ceriano Laghetto (MB)
Tel +39 02 96460902 Fax +39 02 96468606



(EN) ATTENTION!

- Before connecting the electrical cables make sure that the power supply is off.
- The traffic lights have to be installed by qualified technical staff only.
- Used vacuum cleaners still contain many recyclable materials. Therefore please take used vacuum cleaners to your retailer or recycling center so that they can be recycled.



(IT) ATTENZIONE!

Prima di effettuare i collegamenti assicurarsi che l'alimentazione sia staccata. L'installazione deve essere effettuata da personale qualificato. Gli apparecchi dismessi contengono materiali preziosi. Si consiglia pertanto di restituire l'apparecchio dismesso al proprio rivenditore o presso centro di riciclaggio.



(DE) ACHTUNG!

Bevor Sie die ampel berühren, versichern Sie sich dass die Spannung ausgeschaltet ist.

Die Installation darf nur von einem Fachmann ausgeführt werden.

Altgeräte enthalten vielfach noch wertvolle Materialien. Geben Sie deshalb Ihr ausgedientes Gerät bei Ihrem Händler bzw. einem Recyclingcenter zur Wiederverwertung ab.



(FR) ATTENTION!

Avant d'effectuer les branchements électriques s'assurer que l'alimentation soit débranchée.

L'installation ne doit être effectuée que par du personnel qualifié.

Les appareils usagés contiennent souvent des matériaux précieux.

Remettez donc votre appareil usagé à votre revendeur ou à un centre de recyclage pour la revalorisation.



(ES) ATENCIÓN!

Antes de intervenir sobre el dispositivo asegurarse de que la alimentación esté desconectada.

La instalación debe ser efectuada para personal cualificado.

Los aparatos usados contienen aún muchos materiales valiosos. Por este motivo entregar los aparatos usados en el comercio habitual o en el centro de reciclaje para su reaprovechamiento.

H.T.C. GROUP SRL

Via Milano, 8 - 20816 Ceriano Laghetto (MB)

Tel +39 02 96460902 Fax +39 02 96468606

H.T.C. GROUP SRL

Via Milano, 8 - 20816 Ceriano Laghetto (MB)

Tel +39 02 96460902 Fax +39 02 96468606