

:ACCESSORI



ACCESSORI - (AJ00605)

Cover per caricabatteria
ISTRUZIONI PER L'INSTALLAZIONE

Battery cover
INSTRUCTIONS FOR INSTALLATIONS

1

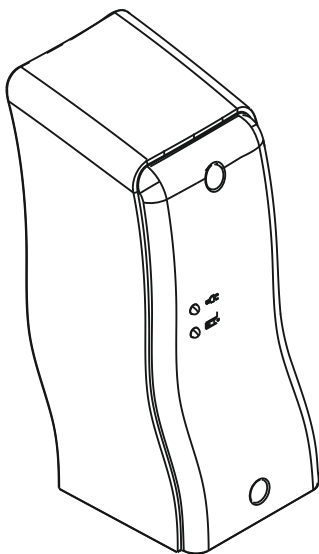

2

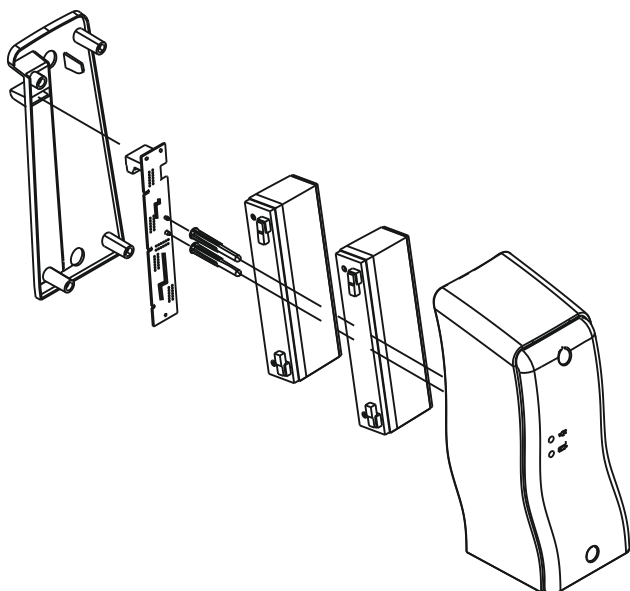

3

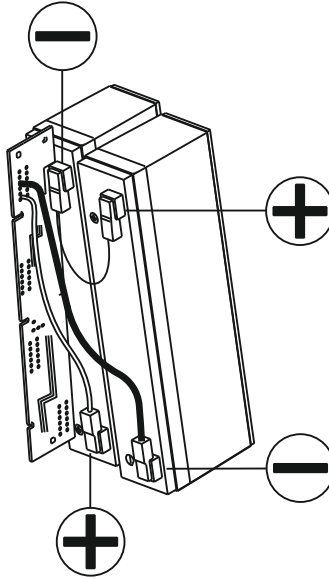

4

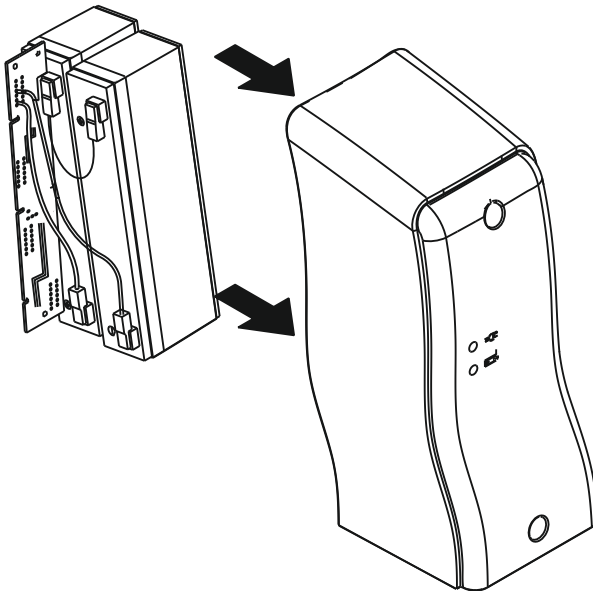

5

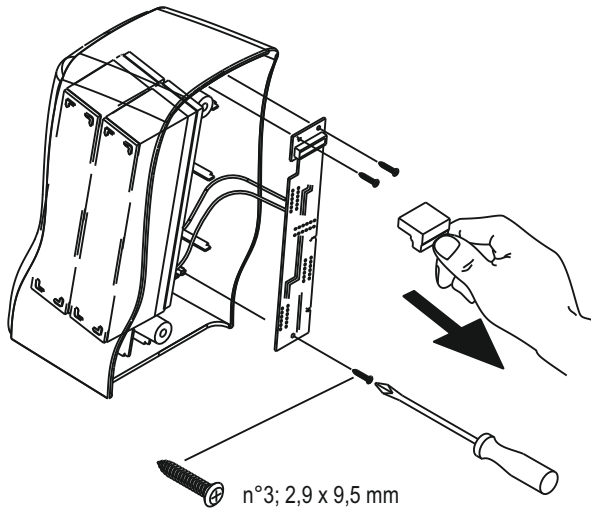

6

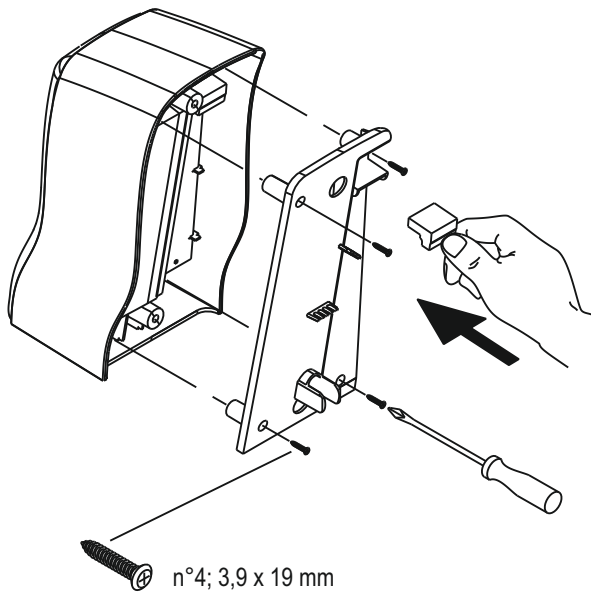

7

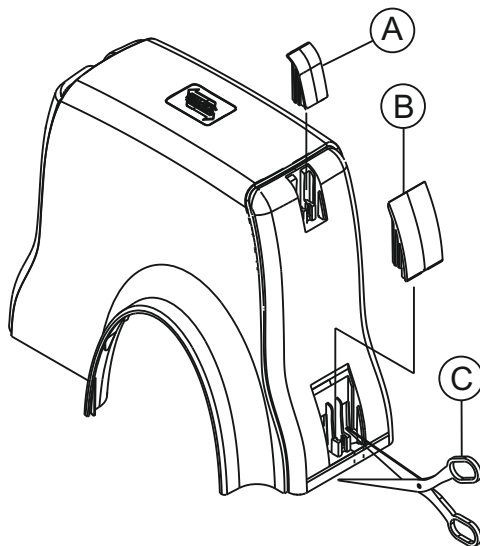

8

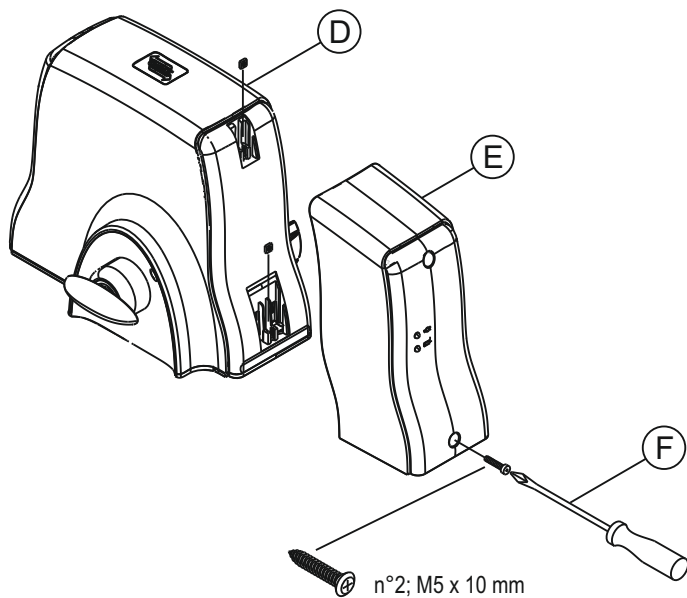

I

MONTAGGIO COVER BATTERIA

Codice AJ00605 (7 - 8)

- | | |
|--|--|
| 1 - Eliminare i tappi (A - B, 7) | 4 - Appoggiare la cover caricabatteria (E - 8) |
| 2 - Tagliare il cofano per il passaggio dei cavi (C - 7) | 5 - Avvitare le viti per il fissaggio (F - 8) |
| 3 - Inserire dadi quadrati (D - 8) | |

UK

FITTING THE BATTERY COVER

Code AJ00605 (7 - 8)

- | | |
|--|--|
| 1 - Remove the caps (A - B, 7) | 4 - Position the battery charger cover (E - 8) |
| 2 - Cut the casing for the cables to run through (C - 7) | 5 - Tighten the retaining screws (F - 8) |
| 3 - Insert the square nuts (D - 8) | |

F

MONTAGE COUVERCLE BATTERIE

Code AJ00605 (7 - 8)

- | | |
|--|--|
| 1 - Eliminer les protections (A - B, 7) | 4 - Poser le couvercle chargeur batterie (E - 8) |
| 2 - Couper le capot pour le passage des câbles (C - 7) | 5 - Visser les vis pour la fixation (F - 8) |
| 3 - Insérer les écrous carrés (D - 8) | |

D

MONTAGE DES BATTERIE-COVERS

Code AJ00605 (7 - 8)

- | | |
|---|--|
| 1 - Die Stöpsel entfernen (A - B, 7) | 4 - Das cover für das batterie-ladegerät (E - 8) anlegen |
| 2 - Die Haube zur Durchführung der Kabel einschneiden (C - 7) | 5 - Die Befestigungsschrauben anziehen (F - 8) |
| 3 - Die Muttern quadrate einsetzen (D - 8) | |

E

MONTAJE TAPA BATERÍA

Código AJ00605 (7 - 8)

- | | |
|---|---|
| 1 - Retire los tapones (A - B, 7) | 4 - Apoye la tapa del cargador de baterías (E - 8) |
| 2 - Corte el capó para que pasen los cables (C - 7) | 5 - Enrosque los tornillos para la fijación (F - 8) |
| 3 - Introduzca tuercas cuadros (D - 8) | |

P

MONTAGEM COBERTURA BATERIA

Código AJ00605 (7 - 8)

- 1 - Eliminar as tampas (A - B, 7)
- 2 - Cortar a tampa para a passagem dos cabos (C - 7)
- 3 - Inserir porcas quadrados (D - 8)
- 4 - Apoiar a cobertura do carregador de bateria (E - 8)
- 5 - Atarraxar os parafusos para a fixação (F - 8)

NL

MONTAGE BATTERIJKAP

Code AJ00605 (7 - 8)

- 1 - Haal de doppen (A - B, 7) weg
- 2 - Snij doorgangen voor de kabels uit de behuizing (C - 7)
- 3 - Plaats de vierkantsmoeren (D - 8)
- 4 - Houd de batterijkap ertegen (E - 8)
- 5 - Draai de schroeven aan voor bevestiging (F - 8)

GR

ΜΟΝΤΑΡΙΣΜΑ COVER ΜΠΑΤΑΡΙΑΣ

Προαιρετικός κωδικός AJ00605(7 - 8)

- 1 - Απομακρύνετε τα πώματα (A - B, 7)
- 2 - Κόψτε το καπό για τη διέλευση των καλωδίων (C - 7)
- 3 - Εισάγετε τα παξιμάδια στα πλαίσια (D - 8)
- 4 - Αποθέστε το cover φορτιστή μπαταρίας (E - 8)
- 5 - Βιδώστε τις βίδες για τη στερέωση (F - 8)

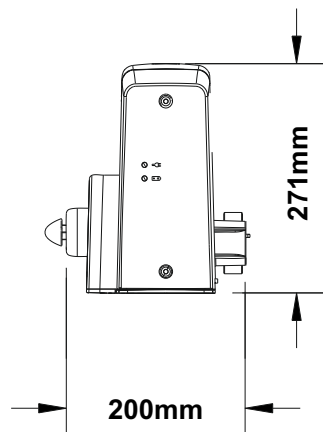
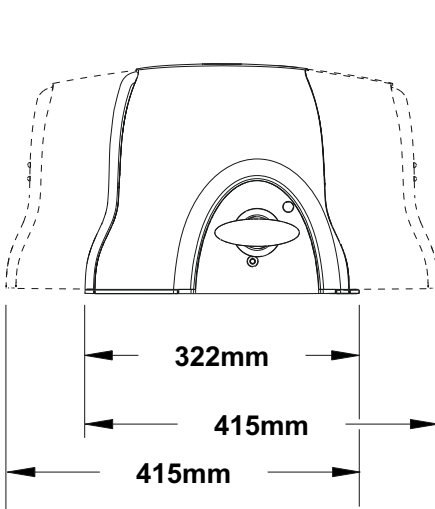

9

GIBIDI

G.I.B.I.D.I. S.r.l.

Via Abetone Brennero, 177/B
46025 Poggio Rusco (MN) - ITALY
Tel. +39.0386.52.20.11
Fax +39.0386.52.20.31
E-mail: comm@gibidi.com

Numero Verde: 800.290156

www.gibidi.com

