

G:B:D:

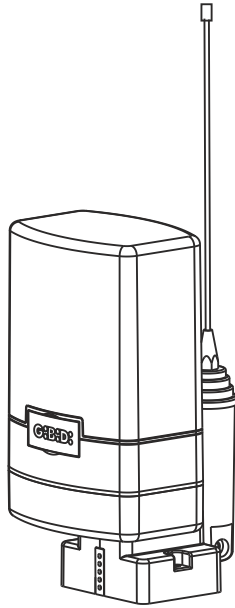

:DSL

CE UK
CA







DSL70750 - (70750)

Lampeggiante Led
ISTRUZIONI PER L'INSTALLAZIONE

Led Flashing light
INSTRUCTIONS FOR INSTALLATIONS



I	UK	F	E
D	P	NL	GR



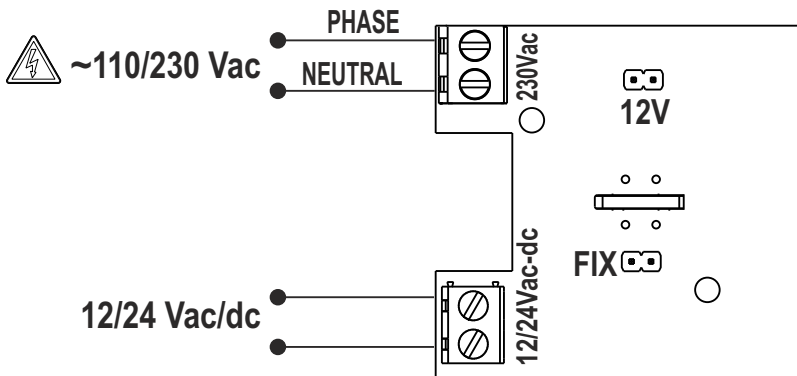

CARATTERISTICHE TECNICHE / TECHNICAL CHARACTERISTICS

DSL 70750 (70750)	
	110-230 Vac 50/60 Hz 12-24 Vac/dc
	24Vdc 1W
	  2/sec.
	Ø 0,75 mm

COLLEGAMENTO ALIMENTAZIONE / POWER SUPPLY CONNECTION



12V	IN
	24Vac/dc
	12Vac/dc

FIX	OUT
	 2/sec.
	



A: cod. 70187 **Optional**



B: cod. AU02810 **Optional**
cod. AU02820 **Optional**



C: cod. AU02750

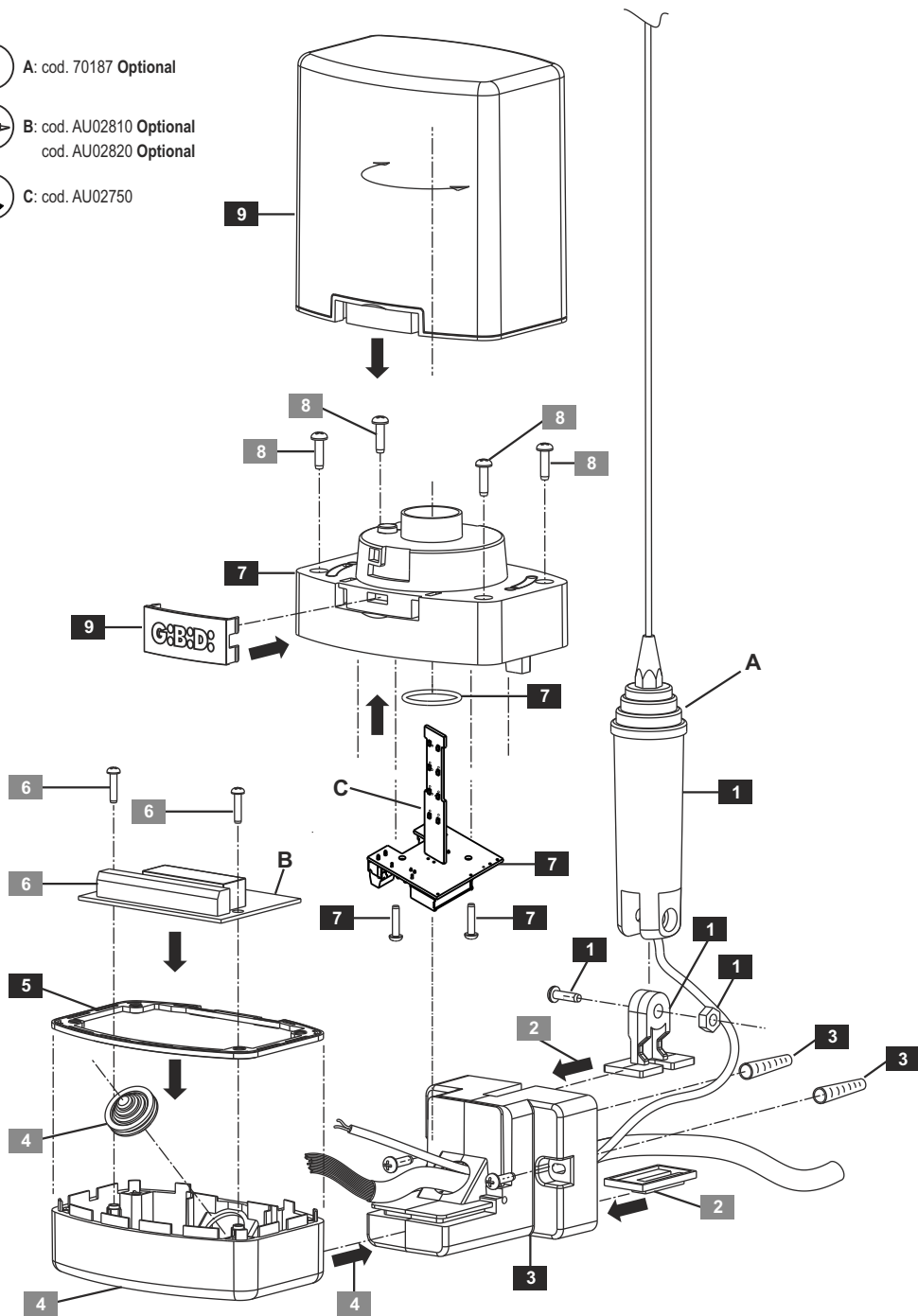

1

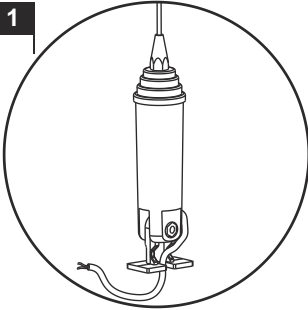

2A

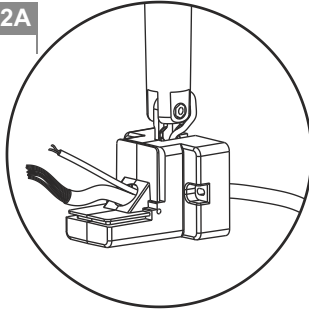

2B

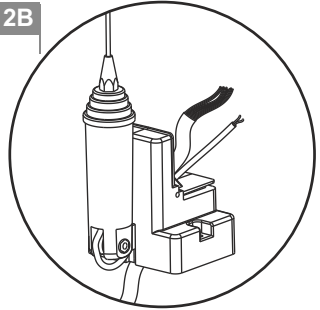

3

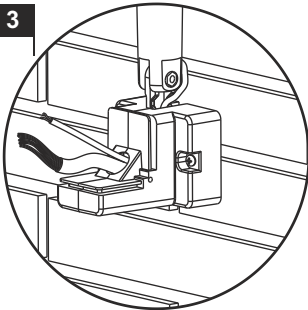

4

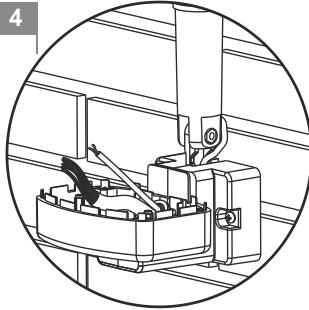

5

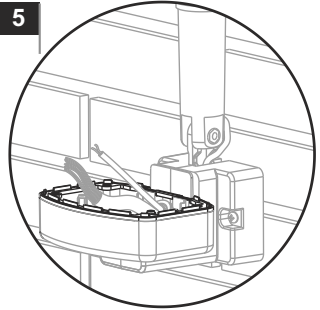

6

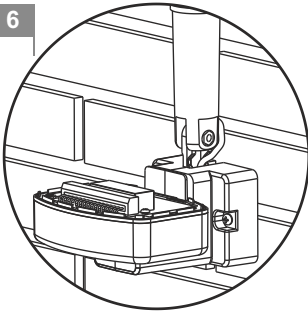

7

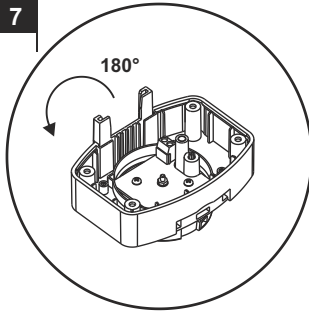

8

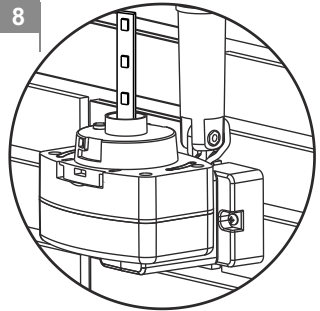

9

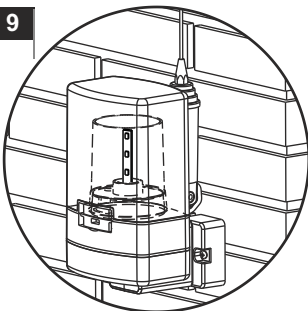

2A

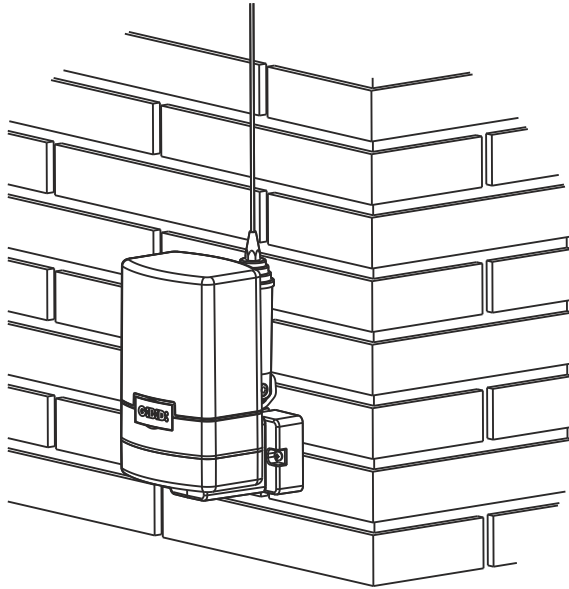

2B

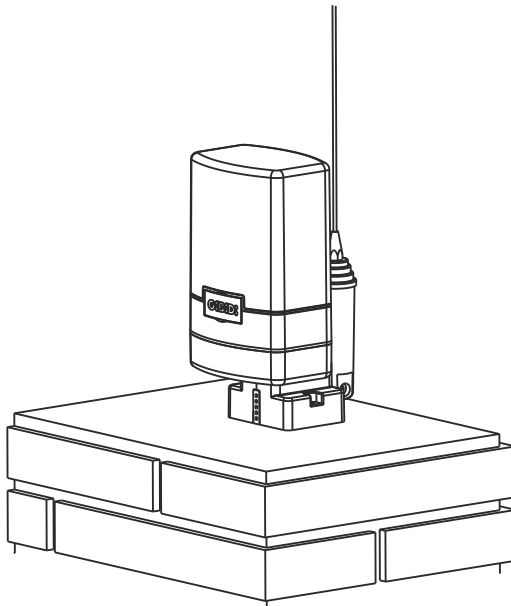

I Grazie per avere scelto GIBIDI.**LEGGERE ATTENTAMENTE QUESTO MANUALE PRIMA DI PROCEDERE ALL'INSTALLAZIONE.**

AVVERTENZE: G.I.B.I.D.I. S.r.l. si riserva la facoltà di modificare i dati tecnici senza avviso, in funzione dell'evoluzione del prodotto.
Dichiarazione del fabbricante UE: Il fabbricante, G.I.B.I.D.I. Srl, dichiara che i prodotti, a cui questo libretto fa riferimento, sono conformi ai requisiti essenziali delle DIRETTIVE 2014/30/UE - 2014/35/UE. La dichiarazione di conformità UE è disponibile all'indirizzo internet <http://conformity.gibidi.com>
SMALTIMENTO: G.I.B.I.D.I. consiglia di riciclare i componenti in plastica e di smaltire in appositi centri abilitati i componenti elettronici evitando di contaminare l'ambiente con sostanze inquinanti.

**UK****Thank you for choosing G.I.B.I.D.I.****PLEASE READ CAREFULLY THIS MANUAL BEFORE PROCEEDING WITH THE INSTALLATION.**

WARNINGS: G.I.B.I.D.I. S.r.l. reserves the right to modify the technical data without prior notice depending on the product development
UE manufacturer declaration: The manufacturer, G.I.B.I.D.I. S.r.l., declares that the products to which this handbook refers comply with the essential requirements of the following DIRECTIVES 2014/30/UE - 2014/35/UE. The EU declaration of conformity is available at <http://conformity.gibidi.com>
UKCA manufacturer declaration: The UKCA declaration is available at: <http://conformity.gibidi.com>
DISPOSAL: G.I.B.I.D.I. advises recycling the plastic components and to dispose of them at special authorised centres for electronic components thus protecting the environment from polluting substances.

**F****Merci d'avoir choisi G.I.B.I.D.I.****NOUS VOUS PRIONS DE BIEN VOULOIR LIRE ATTENTIVEMENT CE MANUEL AVANT DE PROCÉDER À L'INSTALLATION.**

AVERTISSEMENT: G.I.B.I.D.I. S.r.l. se réserve la faculté de modifier les données techniques sans aucun préavis suivant l'évolution de ses produits.
Déclaration du fabricant UE: Le fabricant, G.I.B.I.D.I. S.r.l., déclare que les produits, auxquels se réfère la notice, sont conformes aux conditions essentielles requises par les DIRECTIVES suivantes 2014/30/UE - 2014/35/UE. La déclaration de conformité EU est disponible sur le site <http://conformity.gibidi.com>

ELIMINATION : G.I.B.I.D.I. conseille de recycler les composants en plastique et de remettre les composants électroniques à des centres spécialisés pour éviter de polluer l'environnement avec des substances polluantes.

**E****Gracias por haber elegido G.I.B.I.D.I.****POR FAVOR LEER CON ATENCIÓN ESTE MANUAL ANTES DE PROCEDER CON LA INSTALACIÓN.**

ADVERTENCIAS: La empresa G.I.B.I.D.I. S.r.l. se reserva el derecho de modificar los datos técnicos sin previo aviso, en función de la evolución del producto.
Declaración del fabricante UE: El fabricante, G.I.B.I.D.I. S.r.l., declara que los productos referidos en este folleto cumplen con los requisitos esenciales de las DIRECTIVAS siguientes 2014/30/UE - 2014/35/UE. La declaración UE está disponible en el sitio de internet <http://conformity.gibidi.com>

ELIMINACIÓN: G.I.B.I.D.I. aconseja reciclar los componentes de plástico y llevar los componentes electrónicos a los centros de recogida correspondientes evitando de esta manera la contaminación ambiental con sustancias perjudiciales.

**D****Vielen Dank, dass Sie sich für G.I.B.I.D.I. entschieden haben.****BITTE LESEN SIE VORSICHTIG DIESEN MANUALBEVOR MIT DER ANGLAGE VORZUGEHEN.**

WARNUNGEN: Dieses Produkt wurde in G.I.B.I.D.I. geprüft um die perfekte Entscheidung der merkmale an die geltende vorschriften zu prüfen.
G.I.B.I.D.I. S.r.l. erklärt, dass die Produkte, auf die sich dieses Handbuch bezieht, den grundlegenden Ansprüchen der folgenden RICHTLINIEN entsprechen 2014/30/UE - 2014/35/UE. Die EU-Konformitätserklärung ist unter folgender Internetadresse erhältlich: <http://conformity.gibidi.com>

ENTSORGUNG: G.I.B.I.D.I. empfiehlt, Kunststoffkomponenten dem Recycling zuzuführen und elektronische Komponenten in behördlich genehmigten Zentren zu entsorgen, um die Verschmutzung der Umwelt durch Schadstoffe zu verhindern.

**P****Obrigado por ter escolhido a G.I.B.I.D.I.****LER COM ATENÇÃO ESTE MANUAL ANTES DE PROCEDER COM A INSTALAÇÃO.**

ADVERTÊNCIA: G.I.B.I.D.I. S.r.l. reserva-se o direito de modificar os dados técnicos sem pré-aviso em função de evolução do produto.
Declaração do fabricante da UE: O fabricante, G.I.B.I.D.I. S.r.l., declara que os produtos referidos neste manual estão em conformidade com os requisitos essenciais das seguintes DIRECTIVA 2014/30/UE - 2014/35/UE. A declaração de conformidade da UE está disponível em <http://conformity.gibidi.com>

ELIMINAÇÃO: G.I.B.I.D.I. aconselha a reciclar as componentes em plástico e a eliminar as componentes electrónicas em centros habilitados evitando desta forma poluir o ambiente com substâncias poluentes.

**NL****Dank u voor uw keuze van G.I.B.I.D.I.****LEES DEZE GEBRUIKSAANWIJZING ZEER AANDACHTIG ALVORENS DE INSTALLATIE AAN TE VATTEN.**

WAARSCHUWINGEN: G.I.B.I.D.I. S.r.l. behoudt zich het recht de technische gegevens te wijzigen zonder waarschuwing vooraf, als dat nodig is voor de evolutie van het product.

EU-fabrikantverklaring: De fabrikant, G.I.B.I.D.I. Srl, verklaart dat de producten waarop dit boekje betrekking heeft, voldoen aan de essentiële vereisten van de volgende RICHTLIJNEN 2014/30/UE - 2014/35/UE. De EU-conformiteitsverklaring is beschikbaar op het volgende internetadres: <http://conformity.gibidi.com>

VERWERKING: G.I.B.I.D.I. adviseert om de kunststof componenten te recycleren en de elektronische componenten af te voeren naar erkende inzamelingspunten, om te voorkomen dat het milieu verontreinigd wordt door vervuulende stoffen.

**GR****Ευχαριστούμε που επιλέξατε τα προϊόντα G.I.B.I.D.I.****ΠΑΡΑΚΑΛΟΥΜΕ ΝΑ ΔΙΑΒΑΣΤΕ ΠΡΟΣΕΚΤΙΚΑ ΑΥΤΕΣ ΤΙΣ ΟΔΗΓΙΕΣ ΠΡΙΝ ΤΗΝ ΕΓΚΑΤΑΣΤΑΣΗ**

ΣΗΜΕΙΩΣΗ: Η εταιρία G.I.B.I.D.I. S.r.l διατηρεί το δικαίωμα αλλαγής των τεχνικών προδιαγραφών χωρίς προειδοποίηση, όσον αφορά ανάπτυξη των προϊόντων της. **G.I.B.I.D.I. S.r.l.** δηλώνει ότι τα προϊόντα στα οποία αναφέρεται αυτό το εγχειρίδιο συμμορφώνονται πλήρως με τις ουσιαστικές απαιτήσεις των οδηγιών της Ε.Ε.: 2014/30/UE - 2014/35/UE. Η δήλωση συμμόρφωσης ΕΕ διατίθεται στη διεύθυνση <http://conformity.gibidi.com>

ΔΙΑΘΕΣΗ: Η G.I.B.I.D.I. σας συμβουλεύει να ανακυκλώσετε τα πλαστικά εξαρτήματα και να διαθέσετε τα ηλεκτρονικά εξαρτήματα μετά την απαίωση τους, σε εξειδικευμένα κέντρα που υπάρχουν για τον σκοπό αυτό, συμβάλλοντας έτσι στην προστασία του περιβάλλοντος από τις παρενέργειες της μόλυνσης.



- I** Prima di procedere con l'installazione bisogna predisporre a monte dell'impianto un interruttore magneto termico e differenziale con portata massima 10A.
L'interruttore deve garantire una separazione omnipolare dei contatti, con distanza di apertura di almeno 3 mm.
- UK** Before proceeding with installation, fit a magnetothermal and differential switch with a maximum capacity of 10A upstream of the system.
The switch must guarantee omnipolar separation of the contacts with an opening distance of at least 3 mm.
- F** Avant d'effectuer la mise en place, il faut prévoir en amont de l'installation un interrupteur magnétique thermique et différentiel ayant une capacité maximum de 10A.
L'interrupteur doit assurer une séparation omnipolaire des contacts, avec une distance d'ouverture d'au moins 3 mm.
- E** Antes de proceder con la instalación, hay que preparar aguas arriba de la instalación un interruptor térmico y diferencial con capacidad máxima de 10A.
El interruptor debe garantizar la separación omnipolar de los contactos con una distancia de apertura mínima de 3 mm.
- D** Bevor die Installation in Angriff genommen wird, ist vor der Anlage ein bei max. 10A ansprechender Thermomagnet - oder Differentialschalter zu installieren.
Der Schalter muss die allpolige Trennung der Kontakte mit einer Öffnungsweite von mindestens 3 mm garantieren.
- P** Antes de proceder com a instalação é necessário predispor a montante do sistema um interruptor magneto-térmico e diferencial com capacidade máxima de 10A.
O interruptor deve garantir uma separação omnipolar dos contactos, com distância de abertura de, pelo menos, 3 mm.
- NL** Alvorens met de installatie te beginnen, moet u een thermomagnetische schakelaar of een differentiaalschakelaar met een maximale stroomsterkte van 10A stroomopwaarts van de installatie plaatsen.
De schakelaar moet een omnipolaire onderbreking van de contacten waarborgen, met openingsafstand van minstens 3 mm.
- GR** Πριν προχωρήσετε με την εγκατάσταση, τοποθέτηση η magnetothermal διακοπή διαφορικού, με μεγίστη 10Α αναντή της ικανότητας του συστήματος. Ο διακοπτής πρέπει να εγγυώνται omnipolar διαχωρισμό των επαφών με ένα ανοίγμα απόσταση τουλάχιστον 3 mm.

GIBIDI

GI.BI.DI. S.r.l.

Via Abetone Brennero, 177/B
46025 Poggio Rusco (MN) - ITALY
Tel. +39.0386.52.20.11
Fax +39.0386.52.20.31
E-mail: info@gibidi.com

Numero Verde: 800.290156

www.gibidi.com

