

DETTAGLIO C

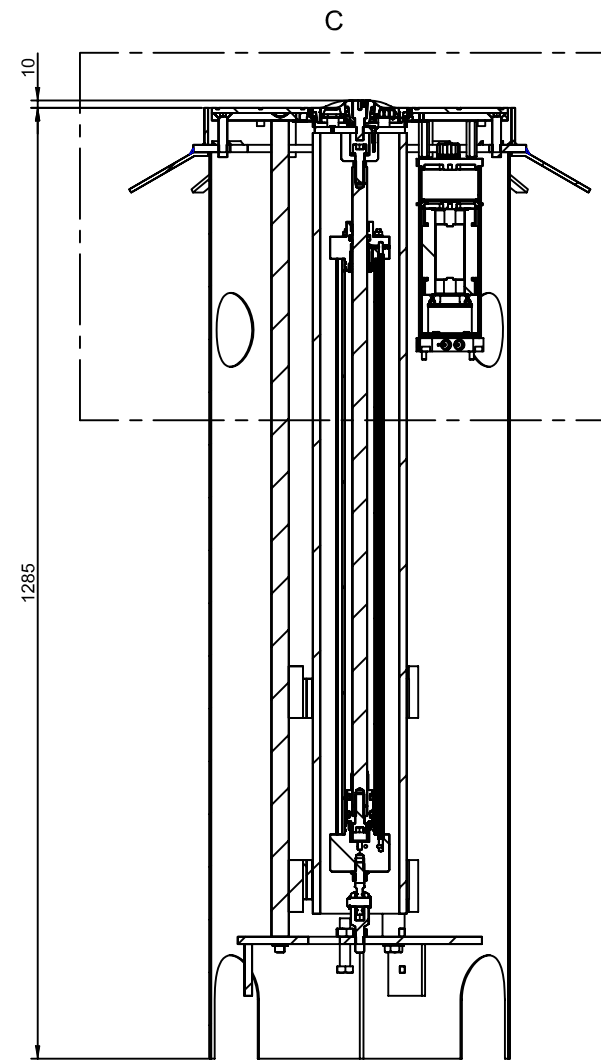

SEZIONE A-A

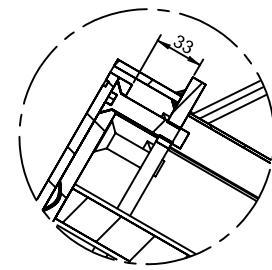
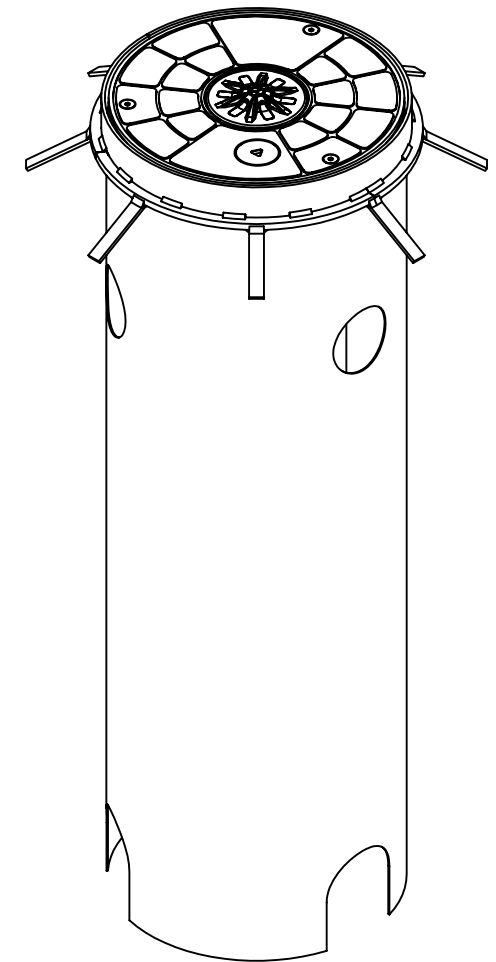

DETTAGLIO D

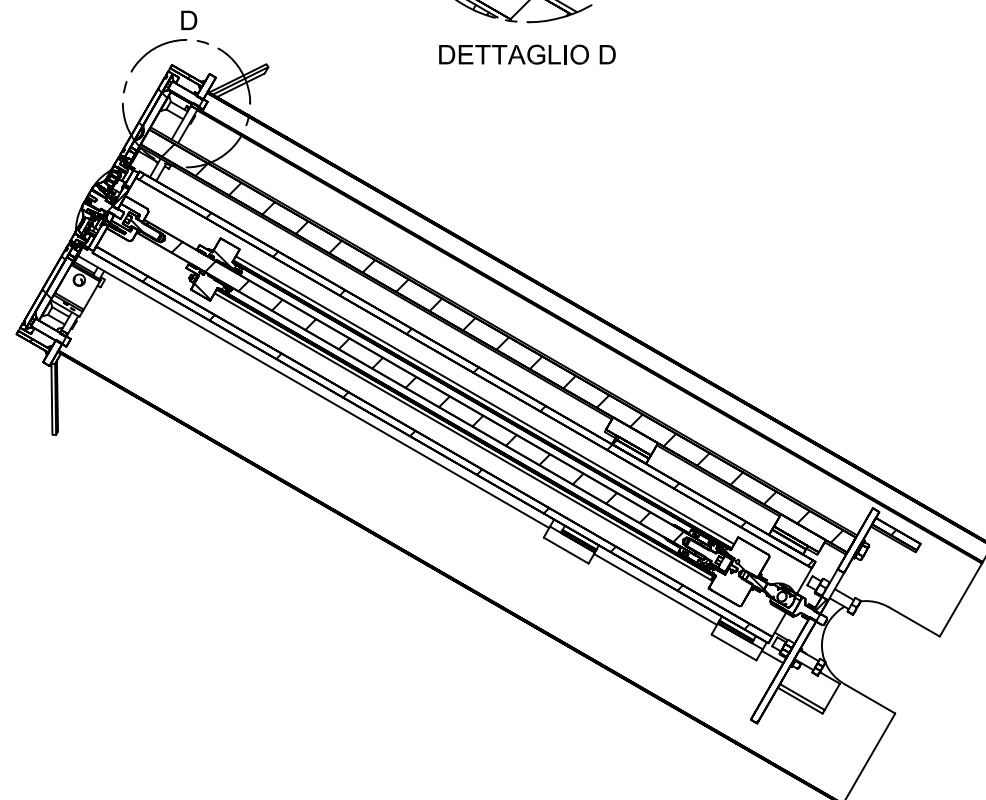

SEZIONE B-B

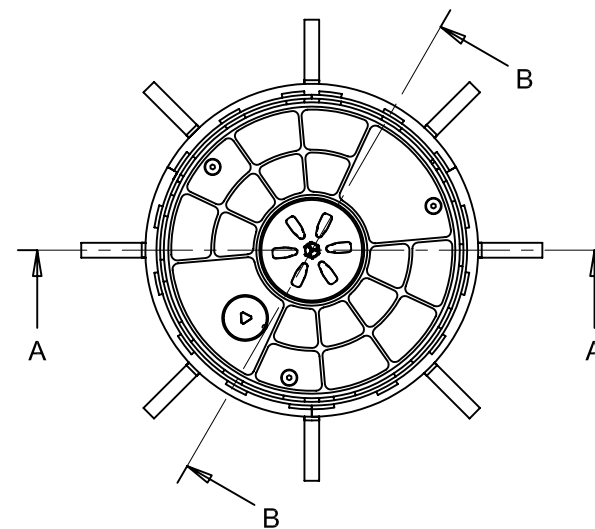

1	03/06/09	REVISIONE GENERALE			D.P.
Rev.	DATA	DESCRIZIONE			FIRMA
TRATTAMENTO :					
MATERIALE :					
DATA	DISEGNATO	CONTROLLATO	IDONEO PER LA PRODUZIONE	MASSA	CODICE
05/08/08	05/08/09	03/06/09		88,20 kg	85000
FIRMA	Cabra	P.D.	D.PINOTTI		
GRUPPO			DISSUASORE DN120 CORSA 700		
DENOMINAZIONE			DISSUASORE OLEOD. E CARCASSA		
SCALA	1:5	TOLLERANZE GENERALI	DISEGNO N.	REV.	
		UNI ISO 2768 -	8546	1	

**GIBIDI**  
 POGGIO RUSCO  
 MANTOVA ITALY