



SWING GATE SYSTEMS.

G·B·D·
CREATIVE AUTOMATIONS

FLOOR

230-24V

*PRODUCT ALSO AVAILABLE
AT 115 VAC

FOTO AUTOMATIC GATES ▶





FLOOR

230-24V *PRODUCT ALSO AVAILABLE AT 115 VAC

Underground hydraulic operators in 230Vac and 24Vdc for swinging gates of medium dimensions and weight, for residential and heavy use.

EASY TO INSTALL

Thanks to the special foundation box. Ambidextrous motor. One-of-a-kind fixing system that allows recovering also the wrong fixing of the doors.

SILENT AND FAST

Only 12 s to open the gate! Extremely silent, because of the materials chosen and tidy finishing of the gears. In 24Vdc version it is possible to adjust the opening speed.

TECHNOLOGICAL AND SAFE

FLOOR has the best hydraulic technology closed-circuit without air. Complete with speed and force regulator, and also with valves to select the reversible, irreversible or fixed modality. In 24Vdc version, it is possible to adjust the anti-crushing sensitivity to make the installation safer, as established by EN12453 standards. European profile key for the unlocking device.

A COMPLETE AND RELIABLE RANGE

FLOOR is much more robust in the new version with opening up to 150° and 180°. It satisfies all the esthetical needs of your gate and is reliable because of the use of high quality materials and the in-depth quality test.

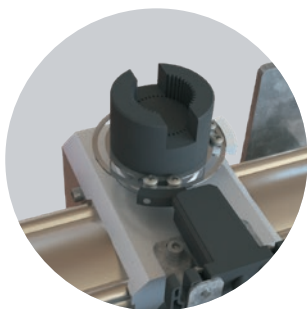

OPTIONAL
LIMIT SWITCH KIT

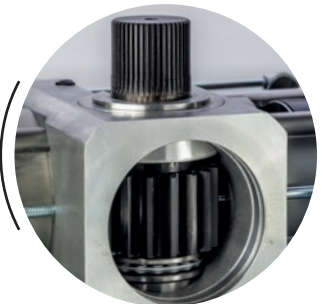

OUTPUT SHAFT MADE
OF TREATED STEEL WITH
THRUST BEARING



SPEED ADJUSTMENT
VALVES AND
MANUAL RELEASE

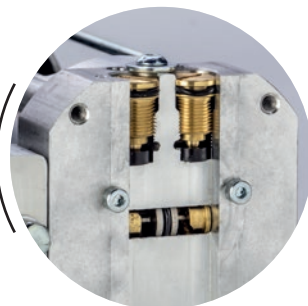

THRUST FORCE AND BRAKE
ADJUSTMENT SCREWS



DOWNLOAD
MORE CONTENT



TECHNICAL FEATURES

	FLOOR 230V 150°	FLOOR 230V 180°	FLOOR 24V 150°	FLOOR 24V 180°
Type of use	HEAVY DUTY	HEAVY DUTY	HEAVY DUTY	HEAVY DUTY
Frequency of use	40%	40%	80%	80%
Motor power supply	230 Vac - 50/60 Hz	230 Vac - 50/60 Hz	24 Vdc	24 Vdc
Absorbed power	190W	190W	120W	120W
Protection degree	IP67	IP67	IP67	IP67
Shaft rotation speed	6°/s	7°/s	6°/s	7°/s
Max torque	320 Nm	300 Nm	320 Nm	300 Nm
Adjustable force	HYDRAULIC	HYDRAULIC	ELECTRONIC	ELECTRONIC
Adjustable speed	YES	YES	YES	YES
Max leaf width	3,0 m *	2,5 m *	3,0 m *	2,5 m *
Max door opening angle	150°	180°	150°	180°
Operating temperature	-20°C +60°C	-20°C +60°C	-20°C +60°C	-20°C +60°C
Encoder/limit switch	OPTIONAL LIMIT SWITCHES	OPTIONAL LIMIT SWITCHES	OPTIONAL LIMIT SWITCHES	OPTIONAL LIMIT SWITCHES
Type of lubrication	OIL GBD PH-03	OIL GBD PH-03	OIL GBD PH-03	OIL GBD PH-03
Weight of the unit	17 kg	16 kg	17 kg	16 kg

* In case of blind leaf or wind presence or leaf over 2,0 m, the use of the electric lock is necessary

APPLICATION DIAGRAM

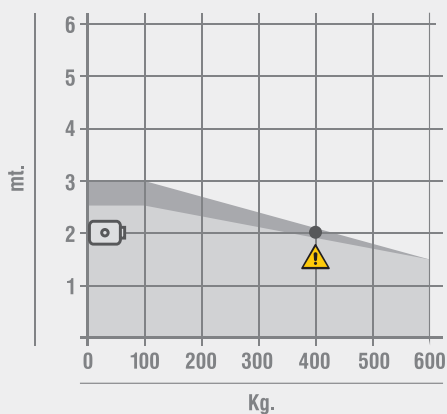

FLOOR 850-854
 FLOOR 880-884
 Electric-lock
 = BAC Limit

INSTALLATION MEASURES

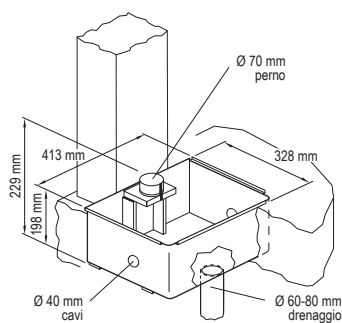

DIMENSIONS

