

DETTAGLIO C

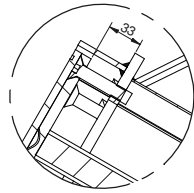

DETTAGLIO D

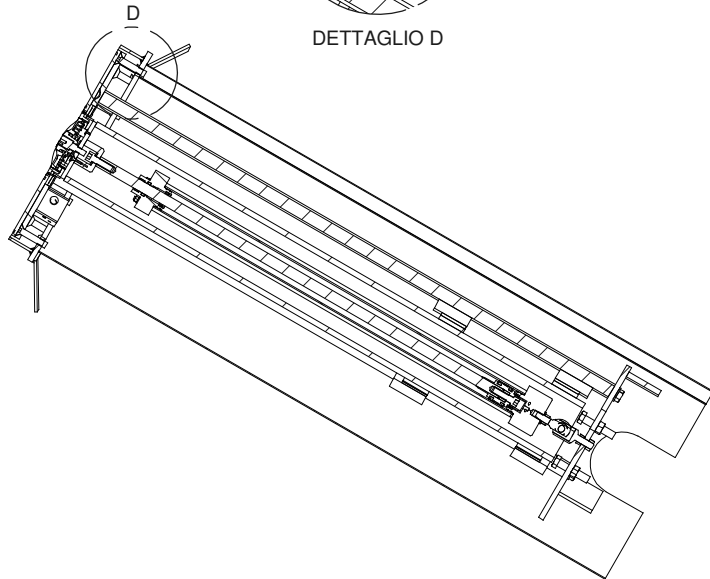

SEZIONE B-B

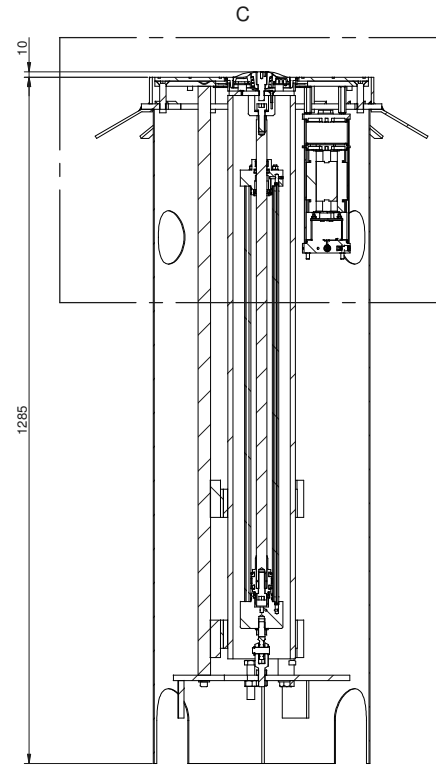

SEZIONE A-A

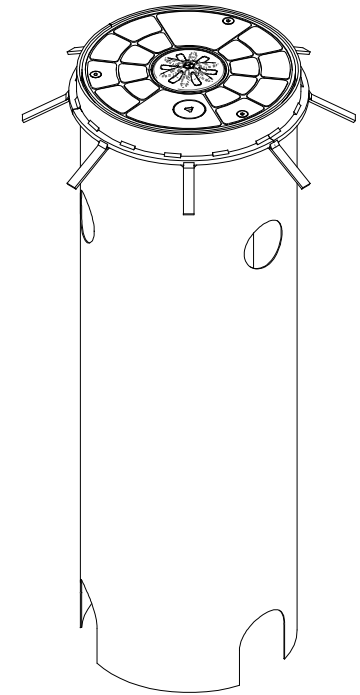
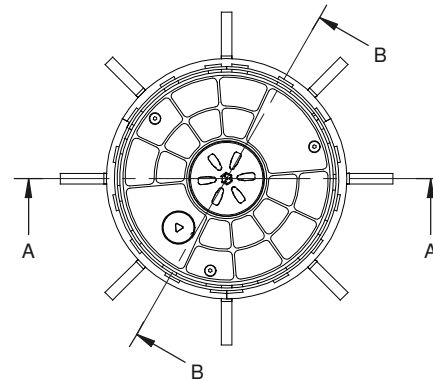

3	25/09/09	DOVE INDICATO			D.P.
2	31/07/09	VITE M12x40 ERA M12x45; SOSTITUITO AGG2400 & AGG2410 CON AGG2390.			D.P.
1	03/06/09	REVISIONE GENERALE			D.P.
Rev.	DATA	DESCRIZIONE			FIRMA
TRATTAMENTO :					
MATERIALE :					
DISEGNATO	CONTROLLATO	IDONEO PER LA PRODUZIONE	MASSA	CODICE	
DATA	05/08/08	05/08/09	25/09/09	88.21 kg	85000
FIRMA	Cabra	P.D.	D.PINOTTI		
GIBIDI		GRUPPO			
POGGIO RUSCO		DISSUASORE DN120 CORSA 700			
MANTOVA - ITALY		DENOMINAZIONE			
		DISSUASORE OLEOD. E CARCASSA			
SCALA	1:5	TOLLERANZE GENERALI	DISEGNO N.	REV.	
UNISO 2768 -		8546	3		